

UNIBOR™





***The NEXT LEVEL of Metal
Cutting Performance,
This Is UNIBOR...***

***BUILT
For Metal.***™



POWER TOOLS

UNIBOR MAGNETIC DRILLS	06
MAGNETIC DRILL SELECTOR CHART	07
CMD400	08
ELITE SERIES	10
E3000	13
E4000	14
E4000 PERMANENT MAGNET	16
E5000 AUTOMATIC	17
E5000 LOW PROFILE	18
E6000	19
E6000 PIVOT	20
E8000	21
SPECIALIST: AIRBOR	22
SPECIALIST: HYDROBOR	23
CHOP SAW AND BLADE RANGE: CHOP SAW 14	24
CHOP SAW AND BLADE RANGE: 14" BLADES	25

ANNULAR CUTTERS

ANNULAR CUTTERS	26
ANNULAR CUTTERS SELECTION CHART	27
24000 SERIES M2 HSS	28
25000 SERIES M42 COBALT	30
27000 SERIES TCT	32
37000 SERIES TCT RAIL	35
ANNULAR CUTTER KITS	36
COUNTERSINKS AND WELDON SHANK STEP DRILLS	38
ARBORS AND ADAPTORS	39

SITEH3RO™

SITEH3RO™	40
HOLDER	42
CAR REAMER	43
STEP REAMER	44
STEP DRILL	45
TAPS	46
KITS	47

POWER TOOL ACCESSORIES

POWER TOOL ACCESSORIES	48
POWER TOOL ACCESSORY SELECTION CHART	49
STEP DRILLS	50
MULTICUT STANDARD STEP DRILL	51
MULTICUT IMPACT STEP DRILL	52
MULTICUT IMPACT PRO STEP DRILL	53
CONE DRILLS	54
CONECUT STANDARD	55
CONECUT IMPACT	56
TCT HOLESAWS	58
TCT SPEEDCUT HOLESAW	59
TCT LONGCUT HOLESAW	60
REAMERS	62
CAR REAMERS	63
STEP REAMERS	64
POWER TOOL ACCESSORY KITS	66



The ULTIMATE Portable Drilling Solution.

MAGNETIC DRILL Selector Chart

Lightweight, powerful and full of features; Unibor magnetic drills take incredible cutting performance to any site, anywhere.

Magnetic Drilling Range	Cutter Capacity (in)	Cutter Depth (in)	Drill Chuck Capacity (in)	Motor Power (W)	Weight (lbs)	Height (in)	Arbor	Stroke (in)	Tapping
-------------------------	----------------------	-------------------	---------------------------	-----------------	--------------	-------------	-------	-------------	---------

The complete all-rounder, our **CMD400** provides high performance on any budget.

CMD400	1-1/2"	2"	1/2"	1100W	30.9lbs	20-5/64"	Weldon	3-11/32"	⊗
---------------	--------	----	------	-------	---------	----------	--------	----------	---

Combining unique technologies, powerful motors and our intuitive Smart Controls; the **ELITE SERIES** is the premier option for magnetic drilling.

E3000	1-1/4"	1-3/8"	1/2"	850W	25.8lbs	16-5/16"	Weldon	2-9/16"	⊗
E4000	2"	2"	1/2"	1200W	29.4lbs	20-1/4"	Weldon	3-3/16"	⊗
E4000 PERM	2"	2"	1/2"	1200W	29.4lbs	20-7/8"	Weldon	3-3/16"	⊗
E5000 AUTO	2"	2"	1/2"	1500W	40.8lbs	23-1/16"	MT2	5-1/2"	⊙
E5000LP	2"	2"	N/A	1200W	24lbs	7-3/64"	Weldon	2-7/16"	⊗
E6000	2-3/8"	3"	1/2"	1500W	34lbs	23-1/6"	MT2	5-1/2"	⊙
E6000 PIVOT	2"	3"	1/2"	1500W	39.6lbs	25-13/64"	MT2	5-15/16"	⊙
E8000	4"	4"	5/8"	2000W	60.7lbs	28-7/8"	MT3	7-7/8"	⊙

Designed for the toughest environments, our **SPECIALIST SERIES** takes Unibor's signature performance to the most challenging situations.

AIRBOR	2"	2"	1/2"	30CFM	28.6lbs	19-11/16"	Weldon	4-11/16"	⊗
HYDROBOR	2-3/8"	2"	N/A	140 bar	52.9lbs	22-13/16"	Weldon	6-11/16"	⊗

CMD400

**HIGH PERFORMANCE,
ON ANY BUDGET.
IDEAL FOR
COUNTERSINKING AND
TWIST DRILLING, THE
CMD400 COMBINES
A POWERFUL MOTOR
WITH THE FLEXIBILITY
OF 6 SPEEDS.**



**Thermal Overload
PROTECTION**



SPECIFICATIONS:

Cutter Capacity	1-1/2"
Depth of Cut	2"
Drill Chuck Capacity	1/2"
No Load Speed	270-610RPM
Motor Specification	1100W
Magnet Adhesion	1800lbs
Length	10-7/16"
Height	20-5/64"
Width	7-3/32"
Magnet Size	6-1/2" x 3-5/32"
Weight	30.9lbs
Motor	120V
Stroke	3-11/32"

KEY SPECIFICATIONS:



**Cutter Capacity
1-1/2"**



**Depth of Cut
2"**



**Twist Drill Capacity
1/2"**



**Weight
30.9lbs**



**1800lbs
Magnet Adhesion**



**Countersink
Capacity
1-3/16"**

KEY FEATURES:

**Variable
SPEED**

*6 electronic speed settings,
ideal for larger diameter cutting,
countersinking and twist drills,
providing maximum versatility*

**Thermal Overload
PROTECTION**

*Designed to shut down in cases
of excessive heat generation,
protecting your motor and machine*

INCLUDED:
Carry Case; Drill Chuck; Hex Keys; Safety Strap; Guard; Integrated Coolant System



Internal Coolant System

Internal CABLING

QUICK Release Interchangeable Handle

DRILLSMART and SMART Controls

LIFTShield TECHNOLOGY

Designed For Performance, BUILT For Metal. This is the **ELITE Series.**

FEATURES available in the series:

DRILLSMART Protection

Safe and efficient working with our integrated LED digital panel display. It shows machine load, prolongs machine life and allows instant restarts after cutting out.

Internal CABLING

Designed to minimize the risk of machine damage, our internal cabling design is essential to prevent potential magnetic drill downtime, keeping you working for longer.

QUICK Release Interchangeable Handle

Effortless convenience with our tool-free, quick-release interchangeable handle. Designed to quickly, easily adjust to tight angles and difficult environments.

LIFTShield TECHNOLOGY

Detects unsafe levels of magnetic adhesion, shutting off the machine and protecting the user.

PERMAMAG

Fitted with patented permanent magnet technology, the machine will be safely magnetised on material just 1/8" thick and stay adhered even if the power is cut, protecting the user and machine.

AUTO Function

Featuring fully automatic drilling, this machine drills the hole, retracts and powers off – ready to be moved safely on to the next hole.

Swivel BASE

This feature is included as standard on the E8000 and allows the machine to be rotated up to 30 degrees, left or right and adjusted up to 3/8" forwards and backwards.

Variable SPEED

24 speeds available for maximum versatility for threading, countersinking and large diameter drilling.

SMART Control

New panel design featuring Smart Control. LED indicators inside each button provide clear instructions, instant safety alerts for magnetic detection, and cutter pressure.

2 Speed GEARBOX

Ideal for optimal speed changes on HSS and TCT Cutters.

4 Speed GEARBOX

Ideal for high capacity drilling applications for maximum performance.

Ideal for PIPE

Designed for drilling pipes with a minimum diameter of 3-1/2" width and standard magnetic drilling applications.

ELITE Series



E3000

THE SINGLE SPEED LIGHTWEIGHT E3000 IS BOTH POWERFUL AND EASILY PORTABLE.



DRILLSMART Protection

SMART Control

LIFTShield TECHNOLOGY

Internal CABLING

QUICK Release Interchangeable Handle

SPECIFICATIONS:

Cutter Capacity	1-1/4"
Depth of Cut	1-3/8"
Drill Chuck Capacity	1/2"
No Load Speed	600RPM
Motor Specification	850W
Magnet Adhesion	2250lbs
Length	10-5/8"
Height	16-5/16"
Width	6-1/2"
Magnet Size	7-1/16" x 3-9/16"
Weight	25.8lbs
Motor	120V
Stroke	2-9/16"

KEY SPECIFICATIONS:



Cutter Capacity
1-1/4"



Depth of Cut
1-3/8"



Twist Drill Capacity
1/2"



Weight
25.8lbs



2250lbs
Magnet Adhesion



850W
Motor

KEY FEATURES:

- **DRILLSMART Protection** for safe and efficient working
- A brand new panel design featuring **SMART Control**
- Tool-free **QUICK Release** interchangeable handle
- Minimize machine damage and prevent magnetic drill downtime with **Internal CABLING**
- **LIFTShield TECHNOLOGY** detects unsafe levels of magnetic adhesion

INCLUDED:

Carry Case; Internal Coolant System; Safety Strap; 4mm A/F Tee Handled Hexagon Key; 3mm Hexagon Key; 6mm Hexagon Key; Drill Chuck Adaptor; Drill Chuck and Key; Safety Glasses

E4000

POWERFUL, PORTABLE AND PRECISE; THIS LIGHTWEIGHT DRILL GETS THE JOB DONE.

Enhanced drilling on any job. Featuring a 2 speed gearbox, the E4000 is ideal for countersinking and larger diameter drilling.

DRILLSMART Protection
Safe and efficient working.



DRILLSMART Protection

SMART Control

Internal CABLING

LIFTShield TECHNOLOGY

2 Speed GEARBOX

QUICK Release Interchangeable Handle



SPECIFICATIONS:

Cutter Capacity	2"
Depth of Cut	2"
Drill Chuck Capacity	1/2"
No Load Speed	GEAR1: 300RPM GEAR2: 600RPM
Motor Specification	1200W
Magnet Adhesion	2250lbs
Length	11-1/4"
Height	20-1/4"
Width	7-5/16"
Magnet Size	7-1/16" x 3-9/16"
Weight	29.4lbs
Motor	120V
Stroke	3-3/16"

KEY SPECIFICATIONS:

Cutter Capacity
2"

Depth of Cut
2"

Twist Drill Capacity
1/2"

Weight
29.4lbs

2250lbs
Magnet Adhesion

Countersink
Capacity
1-3/16"

KEY FEATURES:

- **DRILLSMART Protection** for safe and efficient working
- A brand new panel design featuring **SMART Control**
- Tool-free **QUICK Release** interchangeable handle
- Minimize machine damage and prevent magnetic drill downtime with **Internal CABLING**
- **LIFTShield TECHNOLOGY** detects unsafe levels of magnetic adhesion
- **2 Speed GEARBOX** ideal for optimal speed changes on HSS and TCT cutters

INCLUDED:

Carry Case; Internal Coolant System; Safety Strap; 4mm A/F Tee Handled Hexagon Key; 3mm Hexagon Key; 6mm Hexagon Key; Drill Chuck Adaptor; Drill Chuck and Key; Safety Glasses

ELITE SERIES: Magnetic Drills

E4000 PERM

POWERFUL PERMANENT MAGNET FOR A SAFE HOLD ON SURFACE TREATED MATERIALS.

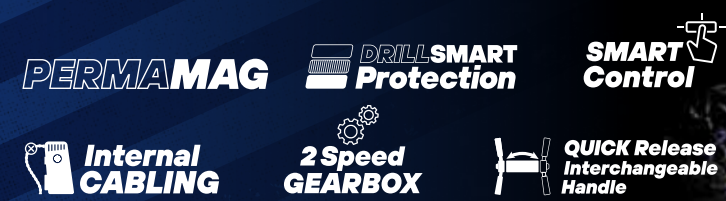

ELITE SERIES: Magnetic Drills

E5000 AUTO

THE NEXT LEVEL OF EFFICIENCY, DESIGNED TO DRILL THROUGH, RETRACT AND POWER DOWN, COMPLETELY AUTOMATICALLY.





SPECIFICATIONS:

Cutter Capacity	2"
Depth of Cut	2"
Drill Chuck Capacity	1/2"
No Load Speed	GEAR1: 300RPM GEAR2: 600RPM
Motor Specification	1200W
Magnet Adhesion	1125lbs
Length	15-1/2"
Height	20-7/8"
Width	7-5/16"
Magnet Size	8-1/4" x 3-9/16"
Weight	29.4lbs
Motor	120V
Stroke	3-3/16"

KEY SPECIFICATIONS:



Cutter Capacity
2"

Depth of Cut
2"

Twist Drill Capacity
1/2"

Weight
29.4lbs

1125lbs
 Magnet Adhesion

Countersink Capacity
1-3/16"

KEY FEATURES:

- **PERMAMAG** technology ensures the magnet stays permanent when the power cuts out
- **DRILLSMART Protection** for safe and efficient working
- A brand new panel design featuring **SMART Control**
- Minimize machine damage and prevent magnetic drill downtime with **Internal CABLING**
- **2 Speed GEARBOX** ideal for optimal speed changes on HSS and TCT cutters
- Tool-free **QUICK Release** interchangeable handle

INCLUDED:

Carry Case; Internal Coolant System; Safety Strap; 4mm A/F Tee Handled Hexagon Key; 3mm Hexagon Key; 6mm Hexagon Key; Drill Chuck Adaptor; Drill Chuck and Key; Safety Glasses

SPECIFICATIONS:

Cutter Capacity	2"
Depth of Cut	2"
Drill Chuck Capacity	1/2"
No Load Speed	GEAR1: 100-265RPM GEAR2: 200-500RPM
Motor Specification	1500W
Magnet Adhesion	3034lbs
Length	15-17/32"
Height	23-1/16"
Width	10"
Magnet Size	7-7/8" x 3-7/8"
Weight	40.8lbs
Motor	120V
Stroke	5-1/2"

KEY SPECIFICATIONS:



Cutter Capacity
2"

Depth of Cut
2"

Twist Drill Capacity
3/4"

Weight
40.8lbs

Tapping Capacity
3/4"

Countersink Capacity
1-3/16"

KEY FEATURES:

- **AUTO Function** fully automatic drilling
- **DRILLSMART Protection** for safe and efficient working
- A brand new panel design featuring **SMART Control**
- Minimize machine damage and prevent magnetic drill downtime with **Internal CABLING**
- **2 Speed GEARBOX** ideal for optimal speed changes on HSS and TCT cutters
- Tool-free **QUICK Release** interchangeable handle
- **LIFTShield TECHNOLOGY** detects unsafe levels of magnetic adhesion
- **Variable SPEED** for larger diameter cutting, providing maximum versatility

INCLUDED:

Carry Case; Internal Coolant System; Safety Strap; 3mm Hexagon Key; 6mm Hexagon Key; Arbor Assembly; 13mm Chuck; Drill Chuck Adaptor; Drill Chuck and Key; Drift; Safety Glasses



ELITE SERIES: Magnetic Drills

E5000LP

MAXIMUM PERFORMANCE,
MINIMUM SIZE; THE E5000LP
IS THE LARGEST CAPACITY
DRILL ON THE MARKET.



- DRILLSMART Protection
- SMART Control
- QUICK Release Interchangeable Handle
- Internal CABLING
- LIFTShield TECHNOLOGY
- Variable SPEED

ELITE SERIES: Magnetic Drills

E6000

LARGE CAPACITY DRILLING,
COUNTERSINKING AND
TAPPING, ALL IN ONE
POWERFUL MACHINE.



- DRILLSMART Protection
- SMART Control
- QUICK Release Interchangeable Handle
- Internal CABLING
- LIFTShield TECHNOLOGY
- Variable SPEED
- 2 Speed GEARBOX

SPECIFICATIONS:

Cutter Capacity	2"
Depth of Cut	2"
Drill Chuck Capacity	N/A
No Load Speed	250-500RPM
Motor Specification	1200W
Magnet Adhesion	2250lbs
Length	13-5/32"
Height	7-3/64"
Width	3-15/16"
Magnet Size	7-9/16" x 3-1/4"
Weight	24lbs
Motor	120V
Stroke	2-7/16"

KEY SPECIFICATIONS:

- Cutter Capacity 2"
- Depth of Cut 2"
- 1200W Motor
- Weight 24lbs
- 2250lbs Magnet Adhesion
- Countersink Capacity 1-3/16"

KEY FEATURES:

- DRILLSMART Protection for safe and efficient working
 - A brand new panel design featuring SMART Control
 - Minimize machine damage and prevent magnetic drill downtime with Internal CABLING
 - Tool-free QUICK Release interchangeable handle
 - LIFTShield TECHNOLOGY detects unsafe levels of magnetic adhesion
 - Variable SPEED for larger diameter cutting, providing maximum versatility
- INCLUDED:**
Carry Case; Fixed Guard; Safety Strap; Coolant bottle; 4mm Hexagonal Wrench; coolant Bottle; Ratchet Handle; Safety Strap; Safety Glasses

SPECIFICATIONS:

Cutter Capacity	2-3/8"
Depth of Cut	3" *
Drill Chuck Capacity	1/2"
No Load Speed	GEAR1: 100-265RPM GEAR2: 200-500RPM
Motor Specification	1500W
Magnet Adhesion	3034lbs
Length	12-3/8"
Height	23-1/16"
Width	7-11/16"
Magnet Size	7-7/8" x 3-7/8"
Weight	34lbs
Motor	120V
Stroke	5-1/2"

KEY SPECIFICATIONS:

- Cutter Capacity 2-3/8"
- Depth of Cut* 3"
- Twist Drill Capacity 3/4"
- Weight 34lbs
- Tapping Capacity 3/4"
- Countersink Capacity 1-3/16"

KEY FEATURES:

- DRILLSMART Protection for safe and efficient working
 - A brand new panel design featuring SMART Control
 - Minimize machine damage and prevent magnetic drill downtime with Internal CABLING
 - Tool-free QUICK Release interchangeable handle
 - LIFTShield TECHNOLOGY detects unsafe levels of magnetic adhesion
 - Variable SPEED for larger diameter cutting, providing maximum versatility
 - 2 Speed GEARBOX ideal for optimal speed changes on HSS and TCT cutters
- INCLUDED:**
Carry Case; Internal Coolant System; 16mm Chuck; Arbor Assembly - 6mm Hexagonal Spanner; Safety Glasses; Arbor Shank; Drift; Safety Strap; 3mm Hexagonal Spanner; Stationery Rings; Pilot Pin

*3" DEPTH CAN ONLY BE ACHIEVED USING A 2 PIECE PILOT PIN



ELITE SERIES: Magnetic Drills

E6000 PIVOT

IDEAL FOR THIN GAUGE MATERIAL AND UNEVEN SURFACES, INCLUDING PIPEWORK AND OTHER TOUGH SURFACES.



- DRILLSMART Protection
- QUICK Release Interchangeable Handle
- SMART Control
- Ideal for PIPE
- PERMAMAG
- Internal CABLING
- Variable SPEED
- 2 Speed GEARBOX

ELITE SERIES: Magnetic Drills

E8000

MAXIMUM DRILLING CAPACITY FOR THE TOUGHEST JOBS.



- DRILLSMART Protection
- QUICK Release Interchangeable Handle
- SMART Control
- Swivel BASE
- 4 Speed GEARBOX
- Internal CABLING
- LIFTShield TECHNOLOGY
- Variable SPEED

SPECIFICATIONS:

Cutter Capacity	2"
Depth of Cut	3" *
Drill Chuck Capacity	1/2"
No Load Speed	GEAR1: 100-265RPM GEAR2: 200-500RPM
Motor Specification	1500W
Magnet Adhesion	1895lbs
Length	12-1/2"
Height	25-13/64"
Width	7-1/2"
Magnet Size	10-7/8" x 7-1/2"
Weight	39.6lbs
Motor	120V
Stroke	5-15/16"

*3" DEPTH CAN ONLY BE ACHIEVED USING A 2 PIECE PILOT PIN

KEY SPECIFICATIONS:

- Cutter Capacity 2"
- Depth of Cut* 3"
- Twist Drill Capacity 3/4"
- Weight 39.6lbs
- Tapping Capacity 3/4"
- Countersink Capacity 1-3/16"

KEY FEATURES:

- Ideal for PIPE with a minimum diameter of 3-1/2"
- DRILLSMART Protection for safe and efficient working
- A brand new panel design featuring SMART Control
- Minimize machine damage and prevent magnetic drill downtime with Internal CABLING
- 2 Speed GEARBOX ideal for optimal speed changes on HSS and TCT cutters
- Tool-free QUICK Release interchangeable handle
- PERMAMAG technology ensures the magnet stays permanent when the power cuts out
- Variable SPEED for larger diameter cutting, providing maximum versatility

INCLUDED:

Carry Case; Internal Coolant System; 16mm Chuck; Arbor Assembly - 6mm Hexagonal Spanner; Safety Glasses; Arbor Shank; Drift; Safety Strap; 3mm Hexagonal Spanner; Stationery Rings; Pilot Pin

SPECIFICATIONS:

Cutter Capacity	4"
Depth of Cut	4"
Drill Chuck Capacity	5/8"
No Load Speed	GEAR1: 45-129RPM GEAR3: 150-434RPM GEAR2: 70-208RPM GEAR4: 240-700RPM
Motor Specification	2000W
Magnet Adhesion	4500lbs
Length	14-9/16"
Height	28-7/8"
Width	9-1/16"
Magnet Size	9" x 4-1/2"
Weight	60.7lbs
Motor	120V
Stroke	7-7/8"

KEY SPECIFICATIONS:

- Cutter Capacity 4"
- Depth of Cut* 4"
- Twist Drill Capacity 1-1/4"
- Weight 60.7lbs
- Tapping Capacity 1-3/16"
- Countersink Capacity 1-5/8"

KEY FEATURES:

- DRILLSMART Protection for safe and efficient working
- A brand new panel design featuring SMART Control
- Minimize machine damage and prevent magnetic drill downtime with Internal CABLING
- Tool-free QUICK Release interchangeable handle
- LIFTShield TECHNOLOGY detects unsafe levels of magnetic adhesion
- Variable SPEED for larger diameter cutting, providing maximum versatility
- 4 Speed GEARBOX ideal for optimal speed changes on HSS and TCT cutters

INCLUDED:

Carry Case; Internal Coolant System; 16mm Chuck; Arbor Assembly - 6mm Hexagonal Spanner; Safety Glasses; Arbor Shank; Drift; Safety Strap; 3mm Hexagonal Spanner; Stationery Rings; Pilot Pin



Specialist: Magnetic Drills

AIRBOR

PNEUMATIC MAGNETIC DRILL FOR USE IN EXPLOSIVE AND HAZARDOUS ENVIRONMENTS.

PERMAMAG



SPECIFICATIONS:

Cutter Capacity	2"
Depth of Cut	2"
No Load Speed	400RPM
Motor Specification	30CFM
Magnet Adhesion	1460lbs
Length	10-1/4"
Height	19-11/16"
Width	11-13/16"
Magnet Size	6 9/32" x 3 15/16"
Weight	28.6lbs
Stroke	4-11/16"

KEY SPECIFICATIONS:



Cutter Capacity
2"



Depth of Cut
2"



1460lbs
Magnet Adhesion



Weight
28.6lbs

INCLUDED:
Carry Case; Hex Keys; Safety Strap; Guard

Specialist: Magnetic Drills

HYDROBOR

HYDRAULICALLY-POWERED MAGNETIC DRILL FOR UNDERWATER APPLICATIONS.

PERMAMAG



SPECIFICATIONS:

Cutter Capacity	2-3/8"
Depth of Cut	2"
No Load Speed	400RPM
Motor Specification	140bar
Magnet Adhesion	1230lbs
Length	13"
Height	22-13/16"
Width	8-7/8"
Magnet Size	7-1/8" x 4-5/8"
Weight	52.9lbs
Stroke	6-11/16"

KEY SPECIFICATIONS:



Cutter Capacity
2-3/8"



Depth of Cut
2"



1230lbs
Magnet Adhesion



Weight
52.9lbs

INCLUDED:
Carry Case; Hex Keys; Safety Strap; Guard



The CHOP SAW 14 and BLADE RANGE

CHOP SAW 14

MAKE LIGHT WORK OF CUTTING STEEL PLATE, SQUARE TUBE, ANGLE IRON, PIPE, TUBE AND SHEET METAL.



SPECIFICATIONS:

No Load Speed	1300RPM
Motor Specification	1800W
Cutter Capacity Box Section	4-3/4" x 4-3/4"
Cutter Capacity Rectangular Section	3-3/4" x 7-9/32"
Cutter Capacity Pipe	ø 5-1/8"
Weight	61.7lbs
Safety Features	Retracting blade guard and metal chip collection chamber.

KEY SPECIFICATIONS:



BEVEL
0-45°



PIPE Cutting Capacity
Ø 5-1/8"



Square Section
MAX thickness
4-3/4" x 4-3/4"



Weight
61.7lbs



Rectangular Section Capacity
3-3/4" x 7-9/32"



1800W
Motor

KEY FEATURES:

- **EFFORTLESS** cutting for steel plate, square tube, angle iron, pipe, tube and sheet metal
- **QUICKER**, more accurate and **SAFER** than conventional abrasive cutting saws
- **SPARK FREE** with no burr
- **SWIVEL VICE** to enable 45° cutting

INCLUDED:
Cermet-tipped Steel Cutting Blade;
Hexagonal Key; Quick Release Vice

The CHOP SAW 14 and BLADE RANGE

14" BLADES

UNIBOR BLADES PRODUCE A CLEAN, COOL CUT, WITH MINIMAL VIBRATION & SPARKS. CERMET TIPPED, OFFERING INCREASED TOOL LIFE.



- Last up to 20 times longer than conventional abrasive discs
- Up to 40% better life than TCT blades
- Triple chip design for added durability

14" Cermet Blades • Specifications

Part No.	Teeth	Bore
STEEL		
RAPBU355FS	66T	1"
ALUMINIUM		
RAPBU355AL	80T	1"
MULTI-PURPOSE		
RAPBU355MP	36T	1"
STAINLESS STEEL		
RAPBU355SS	120T	1"













36
1" A
MAX R



RAPE

ANNULAR Cutters - Choosing the RIGHT cutter for the RIGHT job.

ANNULAR Cutters Selection Chart

ANNULAR CORE CUTTER CATEGORY	24000 SERIES	25000 SERIES	27000 SERIES	37000 SERIES
	High Speed Steel cutters for general holemaking applications.	High Speed Steel with Cobalt increase cutter capability and life.	Carbide Tipped Cutters cut the hardest metals at the highest speeds.	Designed for sustained drilling rail even on the toughest rail applications.
	M2 HSS	M42	TCT	TCT
	<750N	<900N	<1400N	<1400N
 Mild Steel	✓	✓	✓	✗
 Structural Steel	✓	✓	✓	✗
 Construction Steel	✓	✓	✓	✗
 High Strength Steel	✗	✗	✓	✗
 Fine Grain Steel	✗	✗	✓	✗
 Stainless Steel	✗	✓	✓	✗
 Aluminium	✓	✓	✓	✗
 Copper/Brass	✗	✓	✓	✗
 Cast Iron	✗	✗	✓	✗
 Plastics	✓	✓	✗	✗
 Standard Railtrack	✗	✗	✗	✓
 Hardened Railtrack	✗	✗	✗	✓

24000 SERIES M2 HSS

High Speed Steel cutters, ideal for general holemaking applications.

- Fully Precision ground, for higher concentricity and longer tool life
- Custom geometry for enhanced cutting speed
- Made from high quality HSS (High Speed Steel)
- Alternate tooth geometry for smoother cutting
- Also available as custom tapping sizes
- Made in England



Available as individuals and in kits

M2 HSS CUTTERS

Available in kits. See pages 36 and 37 for more information.

Diameter	Decimal	1" D.O.C	2" D.O.C	Diameter	Decimal	1" D.O.C	2" D.O.C	Diameter	Decimal	1" D.O.C	2" D.O.C
7/16"	0.438	24114	24214	12	0.472	MMS12	MML12	27/64"	0.422	T-27641	T-27642
1/2"	0.5	24116	24216	13	0.512	MMS13	MML13	29/64"	0.453	T-29641	T-29642
9/16"	0.563	24118	24218	14	0.551	MMS14	MML14	31/64"	0.484	T-31641	T-31642
5/8"	0.625	24120	24220	15	0.591	MMS15	MML15	17/32"	0.531	T-17321	T-17322
11/16"	0.688	24122	24222	16	0.63	MMS16	MML16	19/32"	0.594	T-19321	T-19322
3/4"	0.75	24124	24224	17	0.669	MMS17	MML17	41/64"	0.641	T-41641	T-41642
13/16"	0.813	24126	24226	18	0.709	MMS18	MML18	21/32"	0.656	T-21321	T-21322
7/8"	0.875	24128	24228	19	0.748	MMS19	MML19	23/32"	0.719	T-23321	T-23322
15/16"	0.938	24130	24230	20	0.787	MMS20	MML20	49/64"	0.766	T-49641	T-49642
1"	1	24132	24232	21	0.827	MMS21	MML21	51/64"	0.797	T-51641	T-51642
1-1/16"	1.063	24134	24234	22	0.866	MMS22	MML22	25/32"	0.844	T-25321	T-25322
1-1/8"	1.125	24136	24236	23	0.906	MMS23	MML23	29/32"	0.906	T-29321	T-29322
1-3/16"	1.188	24138	24238	24	0.945	MMS24	MML24	59/64"	0.922	T-59641	T-59642
1-1/4"	1.25	24140	24240	25	0.984	MMS25	MML25	1-1/32"	1.031	T-11321	T-11322
1-5/16"	1.313	24142	24242	26	1.024	MMS26	MML26	1-9/32"	1.281	T-1-9321	T-1-9322
1-3/8"	1.375	24144	24244	27	1.063	MMS27	MML27				
1-7/16"	1.438	24146	24246	28	1.102	MMS28	MML28				
1-1/2"	1.5	24148	24248	29	1.142	MMS29	MML29				
1-9/16"	1.563	24150	24250	30	1.181	MMS30	MML30				
1-5/8"	1.625	24152	24252	31	1.22	MMS31	MML31				
1-11/16"	1.688	24154	24254	32	1.26	MMS32	MML32				
1-3/4"	1.75	24156	24256	33	1.299	MMS33	MML33				
1-13/16"	1.813	24158	24258	34	1.339	MMS34	MML34				
1-7/8"	1.875	24160	24260	35	1.378	MMS35	MML35				
1-15/16"	1.938	24162	24262	36	1.417	MMS36	MML36				
2"	2	24164	24264	37	1.457	MMS37	MML37				
				38	1.496	MMS38	MML38				
				39	1.535	MMS39	MML39				
				40	1.575	MMS40	MML40				
				41	1.614	MMS41	MML41				
				42	1.654	MMS42	MML42				
				43	1.693	MMS43	MML43				
				44	1.732	MMS44	MML44				
				45	1.772	MMS45	MML45				
				46	1.811	MMS46	MML46				
				47	1.85	MMS47	MML47				
				48	1.89	MMS48	MML48				
				49	1.929	MMS49	MML49				
				50	1.969	MMS50	MML50				



Suitable for Drilling:



Pilot pins included with each cutter:

Code Replacement	Pin Description
USP-1	Pilot Pin for 9/16" and above diameter in 1" D.O.C Cutters
USP-1	Pilot Pin for 7/16" & 1/2" 1" D.O.C Cutters
USP-2	Pilot Pin for 9/16" and above diameter in 2" D.O.C Cutters
USP-2A	Pilot Pin for 7/16" & 1/2" 1" D.O.C Cutters

25000 SERIES M42 COBALT

High Speed Steel with additional Cobalt, for enhanced lifespan.

7/16" to 3"
Diameter

1" to 4"
Depth

M42 COBALT CUTTERS

3/4" Weldon Shank



Up to 30% longer life than M2

Suitable for Drilling:



- Made from M42 cobalt for extended tool life and use on tougher materials
- Designed to withstand higher temperatures and cutting harder materials
- Available from 7/16" to 3" in diameter
- Tapping sizes and 1" to 4" depths of cut available
- All cutters supplied with pilot pins.
- Made in England

Pilot pins included with each cutter:

Code Replacement	Pin Description
USP-1	Pilot Pin for all 1" cutters over 1/2"
USP-1A	Pilot Pin for 25114
USP-2	Pilot Pin for all 2" cutters over 1/2"
USP-2A	Pilot Pin for 25214
USP-3	Pilot Pin for all 3" cutters over 1/2"
USP-4	Pilot Pin for all 4" cutters over 1/2"

Diameter	Decimal	1" D.O.C	2" D.O.C	3" D.O.C	4" D.O.C
7/16"	0.438	25114	25214		
1/2"	0.500	25116	25216		
9/16"	0.563	25118	25218		
5/8"	0.625	25120	25220		
11/16"	0.688	25122	25222		
3/4"	0.750	25124	25224	25324	25424
13/16"	0.813	25126	25226	25326	25426
7/8"	0.875	25128	25228	25328	25428
15/16"	0.938	25130	25230	25330	25430
1"	1.000	25132	25232	25332	25432
1-1/16"	1.063	25134	25234	25334	25434
1-1/8"	1.125	25136	25236	25336	25436
1-3/16"	1.188	25138	25238	25338	25438
1-1/4"	1.250	25140	25240	25340	25440
1-5/16"	1.313	25142	25242	25342	
1-3/8"	1.375	25144	25244	25344	
1-7/16"	1.438	25146	25246	25346	
1-1/2"	1.500	25148	25248	25348	
1-9/16"	1.563	25150	25250	25350	
1-5/8"	1.625	25152	25252	25352	
1-11/16"	1.688	25154	25254	25354	
1-3/4"	1.750	25156	25256	25356	
1-13/16"	1.813	25158	25258	25358	
1-7/8"	1.875	25160	25260	25360	
1-15/16"	1.938	25162	25262	25362	
2"	2.000	25164	25264	25264	
2-1/16"	2.063	25166	25266	25366	
2-1/8"	2.125	25168	25268	25368	
2-3/16"	2.188	25170	25270	25370	
2-1/4"	2.250	25172	25272	25372	
2-5/16"	2.313	25174	25274	25374	
2-3/8"	2.375	25176	25276	25376	
2-7/16"	2.438	25178	25278	25378	
2-1/2"	2.500	25180	25280	25380	
2-9/16"	2.563	25182	25282	25382	
2-5/8"	2.625	25184	25284	25384	
2-11/16"	2.688	25186	25286	25386	
2-3/4"	2.750	25188	25288	25388	
2-13/16"	2.813	25190	25290	25390	
2-7/8"	2.875	25192	25292	25392	
2-15/16"	2.938	25194	25294	25394	
3"	3.000	25196	25296	25396	

Sizes up to 4" diameter available, visit unibor.com for more information.

27000 SERIES TCT

**Tungsten Carbide
Tipped (TCT), for the
toughest materials.**



**Available as
individuals
and in kits**

27000 SERIES TCT

Specialist 3 Step
Alternative Tooth Geometry



Fully Fluted, Hardened
Cutter Body

2 Flat 3/4"
Universal Shank*

*Diameters over 3" have 1-1/4" Weldon Shank

Suitable for Drilling:



- Designed for tough steels (up to 1400N/mm²), aluminium and rail track
- Biggest range of carbide cutters in North America
- Specialist 3 step alternate tooth geometry for the smoothest cut.
- 2-flat universal shank for optimal security and flexibility
- All cutters supplied with Pilot Pin

Pilot pins included with each cutter:

Code Replacement	Pin Description
PILOTU1A	Pilot Pin for 1/2" to 11/16" for 1" D.O.C Cutters
PILOTU1B	Pilot Pin for 3/4" to 3" for 1" D.O.C Cutters
PILOTU2A	Pilot Pin for 1/2" to 11/16" for 2" D.O.C Cutters
PILOTU2B	Pilot Pin for 3/4" to 3" for 2" D.O.C Cutters
TCT-3	Pilot Pin for 3" D.O.C Cutters
TCT-4	Pilot Pin for 4" D.O.C Cutters
TCT-6	Pilot Pin for 6" D.O.C Cutters
TCT-8	Pilot Pin for 8" D.O.C Cutters

Dia	1" D.O.C	2" D.O.C	3" D.O.C	4" D.O.C	6" D.O.C	8" D.O.C
1/2"	27116	27216	27314	27414		
9/16"	27118	27218	27318	27418		
5/8"	27120	27220	27320	27420		
11/16"	27122	27222	27322	27422		
3/4"	27124	27224	27324	27424	27624	
13/16"	27126	27226	27326	27426	27626	27826
7/8"	27128	27228	27328	27428	27628	27828
15/16"	27130	27230	27330	27430	27630	27830
1"	27132	27232	27332	27432	27632	27832
1-1/16"	27134	27234	27334	27434	27634	27834
1-1/8"	27136	27236	27336	27436	27636	27836
1-3/16"	27138	27238	27338	27438	27638	27838
1-1/4"	27140	27240	27340	27440	27640	27840
1-5/16"	27142	27242	27342	27442	27642	27842
1-3/8"	27144	27244	27344	27444	27644	27844
1-7/16"	27146	27246	27346	27446	27646	27846
1-1/2"	27148	27248	27348	27448	27648	27848
1-9/16"	27150	27250	27350	27450	27650	27850
1-5/8"	27152	27252	27352	27452	27652	27852
1-11/16"	27154	27254	27354	27454	27654	27854
1-3/4"	27156	27256	27356	27456	27656	27856
1-13/16"	27158	27258	27358	27458	27658	27858
1-7/8"	27160	27260	27360	27460	27660	27860
1-15/16"	27162	27262	27362	27462	27662	27862
2"	27164	27264	27364	27464	27664	27864
2-1/16"		27266	27366		27666	27866
2-1/8"		27268	27368		27668	27868
2-3/16"		27270	27370		27670	27870
2-1/4"		27272	27372		27672	27872
2-5/16"		27274	27374		27674	27874
2-3/8"		27276	27376		27676	27876
2-7/16"		27278	27378		27678	27878
2-1/2"		27280	27380		27680	27880
2-9/16"		27282	27382		27682	27882
2-5/8"		27284	27384		27684	27884
2-11/16"		27286	27386		27686	27886
2-3/4"		27288	27388		27688	27888
2-13/16"		27290	27390		27690	27890
2-7/8"		27292	27392		27692	27892
2-15/16"		27294	27394		27694	27894
3"		27296	27396		27696	27896
3-1/16"		27298	27398		27698	27898
3-1/8"		272100	273100		276100	278100
3-3/16"		272102	273102		276102	278102
3-1/4"		272104	273104		276104	278104
3-5/16"		272106	273106		276106	278106
3-3/8"		272108	273108		276108	278108

**Available in kits. See pages
36 and 37 for more information.**

27000 SERIES TCT (CONTINUED)

Diameter	2" D.O.C	3" D.O.C	6" D.O.C	8" D.O.C
3-7/16"	272110	273110	276110	278110
3-1/2"	272112	273112	276112	278112
3-9/16"	272114	273114	276114	278114
3-5/8"	272116	273116	276116	278116
3-11/16"	272118	273118	276118	278118
3-3/4"	272120	273120	276120	278120
3-13/16"	272122	273122	276122	278122
3-7/8"	272124	273124	276124	278124
3-15/16"	272126	273126	276126	278126
4"	272128	273128	276128	278128
4-1/16"	272130		276130	278130
4-1/8"	272132		276132	278132
4-3/16"	272134		276134	278134
4-1/4"	272136		276136	278136
4-5/16"	272138		276138	278138
4-3/8"	272140		276140	278140
4-7/16"	272142		276142	278142
4-1/2"	272144		276144	278144
4-9/16"	272146		276146	278146
4-5/8"	272148		276148	278148
4-11/16"	272150		276150	278150
4-3/4"	272152		276152	278152
4-13/16"	272154		276154	278154
4-7/8"	272156		276156	278156
4-15/16"	272158		276158	278158
5"	272160		276160	278160
5-1/16"	272162		276162	278162
5-1/8"	272164		276164	278164

Diameter	6" D.O.C	8" D.O.C
5-3/16"	276166	278166
5-1/4"	276168	278168
5-5/16"	276170	278170
5-3/8"	276172	278172
5-7/16"	276174	278174
5-1/2"	276176	278176
5-9/16"	276178	278178
5-5/8"	276180	278180
5-11/16"	276182	278182
5-3/4"	276184	278184
5-13/16"	276186	278186
5-7/8"	276188	278188
5-15/16"	276190	278190
6"	276192	278192
6-1/16"	276194	278194
6-1/8"	276196	278196
6-3/16"	276198	278198
6-1/4"	276200	278200
6-5/16"	276202	278202
6-3/8"	276204	278204
6-7/16"	276206	278206
6-1/2"	276208	278208
6-9/16"	276210	278210

Diameter	6" D.O.C	8" D.O.C
6-5/8"	276212	278212
6-11/16"	276214	278214
6-3/4"	276216	278216
6-13/16"	276218	278218
6-7/8"	276220	278220
6-15/16"	276222	278222
7"	276224	278224
7-1/16"	276226	278226
7-1/8"	276228	278228
7-3/16"	276230	278230
7-1/4"	276232	278232
7-5/16"	276234	278234
7-3/8"	276236	278236
7-7/16"	276238	278238
7-1/2"	276240	278240
7-9/16"	276242	278242
7-5/8"	276244	278244
7-11/16"	276246	278246
7-3/4"	276248	278248
7-13/16"	276250	278250
7-7/8"	276252	278252
7-15/16"	276254	278254
8"	276256	278256

Available in kits.
See pages 36 and 37
for more information.



37000 SERIES TCT RAIL

Diameter	SKU	Diameter	SKU
3/4"	37124	1-3/16"	37138
7/8"	37128	1-1/4"	37140
15/16"	37130	1-5/16"	37142
1"	37132	1-3/8"	37144
1-1/16"	37134	1-7/16"	37146
1-1/8"	37136	1-1/2"	37148

Twist Lock Shank



Pilot pins included with each cutter:

Code Replacement	Pin Description
PILOTS	1" D.O.C Pilot Pin

Suitable for Drilling:



STANDARD RAIL RACK



HARDENED RAIL RACK

- Specialist Flute Design for Rail Cutting applications
- The ultimate in rail cutting, designed to deliver
- 30% longer life than standard rail cutters
- Carbide tipped teeth, ideal for hardened rail track and running in drills above 300RPM

ANNULAR Cutter Kits



**Make fabrication easier,
with the best kit:**

- **Material types: HSS & TCT**
- **Kit depths: 1" & 2"**
- **Kit sizes: 3, 6 & 24 piece**



24000 SERIES M2 HSS Cutter Kits

Kit	Part Numbers	SKU	Size Range	Shank
3 Piece, 1" Depth Cutter Kit	24118, 24120, 24126	SKIT-03	9/16", 5/8", 13/16"	3/4" Weldon Shank
3 Piece, 2" Depth Cutter Kit	24218, 24220, 24226	SKIT-04	9/16", 5/8", 13/16"	3/4" Weldon Shank
6 Piece, 1" Depth Cutter Kit	24118, 24120, 24122, 24124, 24126, 24130	SKIT-01	9/16", 5/8", 11/16", 3/4", 13/16", 15/16"	3/4" Weldon Shank
6 Piece, 2" Depth Cutter Kit	24218, 24220, 24222, 24224, 24226, 24230	SKIT-02	9/16", 5/8", 11/16", 3/4", 13/16", 15/16"	3/4" Weldon Shank
24 Piece, 1" Depth of Cutter Kit	24118, 24120, 24122, 24124, 24126, 24128, 24130, 24132, 24134, 24136, 24138, 24140, 24142, 24144, 24146, 24148, 24150, 24152, 24154, 24156, 24158, 24160, 24162, 24164 + 7 X USP-1	BigKit01	9/16", 5/8", 11/16", 3/4", 13/16", 7/8", 15/16", 1", 1-1/16", 1-1/8", 1-3/16", 1-1/4", 1-5/16", 1-1-3/8", 1-7/16", 1-1/2, 1-9/16", 1-5/8", 1-11/16", 1-3/4", 1-13/16", 1-7/8", 1-15/16" & 2"	3/4" Weldon Shank

27000 SERIES TCT Cutter Kits

Kit	Part Numbers	SKU	Size Range	Shank
3 Piece, 1" Depth Cutter Kit	27118, 27120, 27126	TCTKIT-01	9/16", 5/8", 13/16"	2 Flat 3/4" Universal Shank
3 Piece, 2" Depth Cutter Kit	27218, 27220, 27226	TCTKIT-02	9/16", 5/8", 13/16"	2 Flat 3/4" Universal Shank
6 Piece, 1" Depth Cutter Kit	27118, 27120, 27122, 27124, 27126, 27130	TCTKIT-03	9/16", 5/8", 11/16", 3/4", 13/16", 15/16"	2 Flat 3/4" Universal Shank
6 Piece, 2" Depth Cutter Kit	27218, 27220, 27222, 27224, 27226, 27230	TCTKIT-04	9/16", 5/8", 11/16", 3/4", 13/16", 15/16"	2 Flat 3/4" Universal Shank



COUNTERSINKS AND WELDON SHANK STEP DRILLS

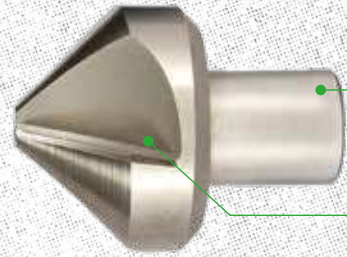

Made From High Quality M2 High Speed Steel

82° Countersink

Suitable for Drilling:



- Manufactured from extremely tough high speed steel
- Suitable for all types of portable drills with a 3/4" Shank
- 3 Cutting Edges, smooth chamfering, and high surface finish

COUNTERSINKS

SKU	Product Description
20ZB115	1" Diameter, 82° Countersink
20ZB116	1-1/2" Diameter, 82° Countersink
20ZB117	2" Diameter, 82° Countersink

WELDON Shank 3 Step Drill

SKU	Step Depth	SKU	Step 1	Step 2	Step 3
Starter	1"	IPSD4456	7/16"	1/2"	9/16"
		IPSD6375	5/8"	11/16"	3/4"
		IPSD8194	13/16"	7/8"	15/16"
Follow on	1"	IPSD1011	1"	1-1/16"	1-1/8"
		IPSD1213	1-3/16"	1-1/4"	1-5/16"
		IPSD1415	1-3/8"	1-7/16"	1-1/2"
		IPSD1617	1-9/16"	1-5/8"	1-11/16"
		IPSD1819	1-3/4"	1-13/16"	1-7/8"
		IPSD1921	1-5/16"	2"	2-1/16"

- Designed to both start new and expand existing holes, on site or in the workshop
- Fitted with a 3/4 Weldon Shank
- Ranging from 5/16" up to 2-3/16" and between 1/2" in 1" inch deep
- Available as both starter and follow on tools

Starter Point for Starting New Holes



Weldon Shank 1/2" Steps

1" depth - from 5/16" to 2-2/16" diameter Follow On Tool

Suitable for Drilling:



WELDON Shank 5 Step Drill

SKU	Step Depth	SKU	Step 1	Step 2	Step 3	Step 4	Step 5
Starter	1/2"	IPSD3156	5/16"	3/8"	7/16"	1/2"	9/16"
		IPSD3863	3/8"	7/16"	1/2"	9/16"	5/8"
		IPSD6994	11/16"	3/4"	13/16"	7/8"	15/16"
Follow on	1/2"	IPSD1013	1"	1-1/16"	1-1/8"	1-3/16"	1-1/4"
		IPSD1316	1-5/16"	13/8"	1-7/16"	1-1/2"	1-9/16"
		IPSD1619	1-5/8"	1-11/16"	1-3/4"	1-13/16"	1-7/8"
		IPSD1922	1-15/16"	2"	2-2/16"	2-1/8"	2-3/16"

ARBORS AND ADAPTORS

Magnetic Drill ARBORS

SKU	Product Description
ARBO15	2 Morse Taper Short Arbor, 2 Set Screws for 3/4" Shank
ARBO02	Standard length 2 Morse Taper Arbor, 2 Set Screws for 3/4" Shank
ARBOIL2	Number 2 morse taper arbor with coolant feed
M0505	2 Morse Taper, QuickHitch 3/4" Shank Arbor
ARBO03	3 Morse Taper Arbor, 3/4", 2 Set Screw
ARBO04	4 Morse Taper to 3/4" Annular Cutter Arbor
ARBOIL3	3 Morse Taper Arbor with Coolant Feed, 3/4" 2 Set Screw
ARBQR03	3 Morse Taper Quick Hitch Arbor, 3/4" Shank
ARBO20	3 Morse Taper, 1-1/4" Arbor, 2 set screws
ARBO17	3 Morse Taper Oil Feed Arbor with 3" Cut Depth, 3/4" 2 Set Screw



3-Jaw Chuck ADAPTERS

SKU	Product Description
CHUC05	1/2" Chuck and Key, with 3/4" Shank (for EQ35N or any machine)
CHUC04	5/8" Chuck & Key, 2 Morse Taper (for EQ50/E40 or any 2 MT)
CHUC08	3/4" Chuck & Key, 3 Morse Taper (for EQ100/E100 or any 3 MT)



EXTENSION & ARBORS

SKU	Product Description
EX01	1" extension, 3/4" Male to 3/4" Female
EX02	2" extension, 3/4" Male to 3/4" Female
EX03	3" extension, 3/4" Male to 3/4" Female
EX04	4" extension, 3/4" Male to 3/4" Female
ARBORR8	Bridgeport/R8 Adapter for 3/4" Shank Annular Cutters
ADAPT1	3/4" Weldon Milling Machine Adapter, 3/4" shank
CHUC11	1/2" 3-flat to 3/4" Female, for use in 3 Jaw Chucks



COOLCUT™ Coolant

SKU	Product Description
OIL 01	1 Gallon concentrate, makes 11 gallons



OIL 01

SITEH3RO™

Turn your Impact Wrench into a multipurpose metal working machine

PATENT PENDING

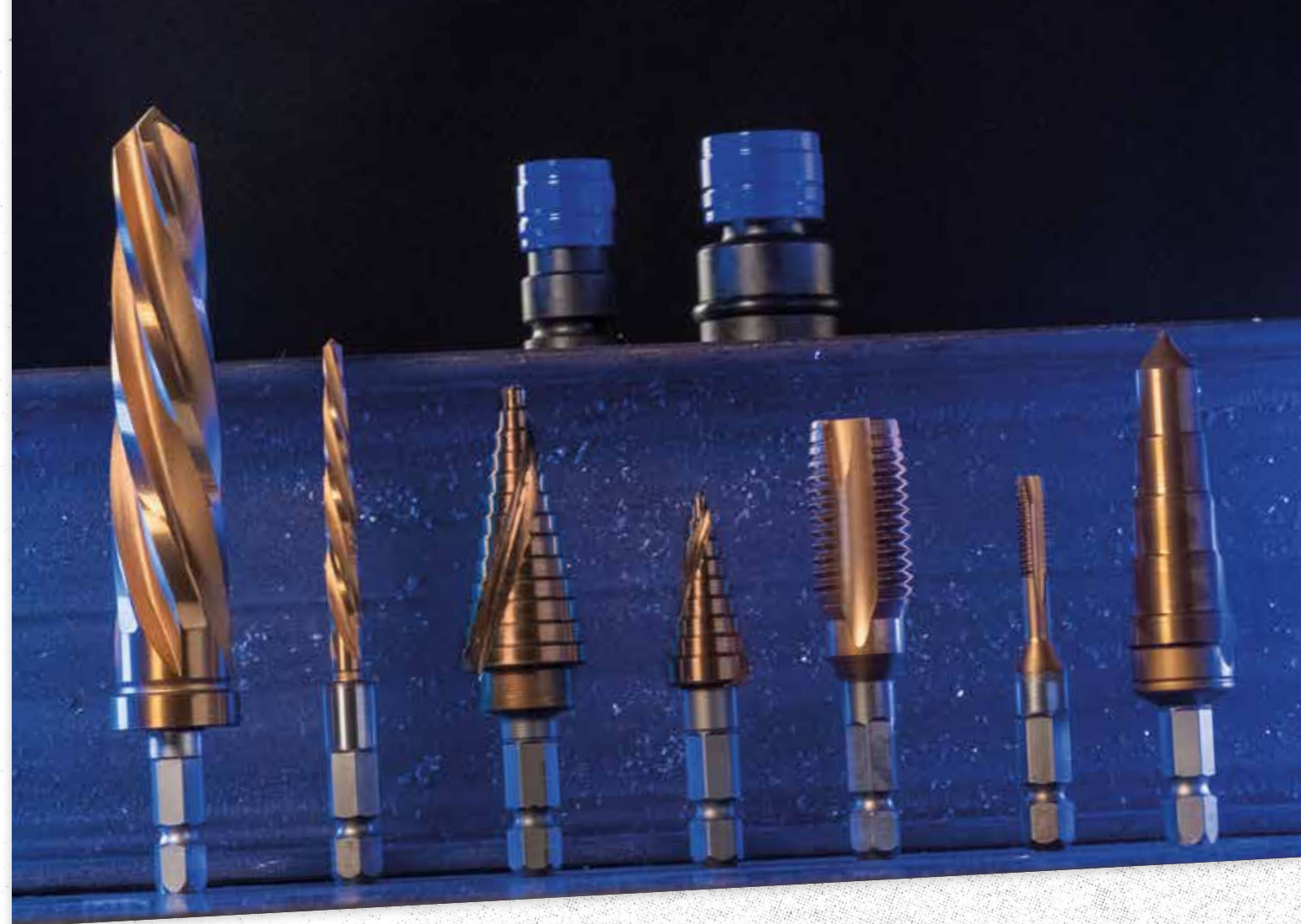

Connect Click GO

Drill new, expand, thread and align holes for the major diameters

SMOOTH, EASY CUT

75%
Longer life with SITEH3RO™ coating

Suitable for 1/2" and 3/4" Impact Wrenches (holder dependent)

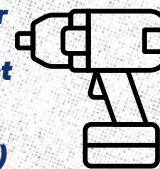

Make **NEW HOLES** with Step Drills & Step Reamers

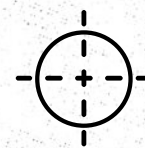

ALIGN HOLES with Car Reamers

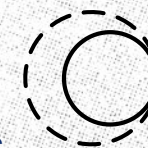

THREAD HOLES with Taps



EXPAND HOLES with Step Drills and Step & Car Reamers

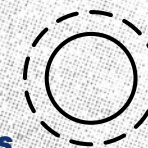

SITEH3RO™: Holder

SITEH3RO™

SITEH3RO™ HOLDER

Int. Pat. Pending. WO2024/100390



High Temperature Tested to 356°F

Quick Release

Suitable for 1/2" and 3/4" Impact Wrenches

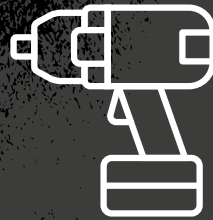

SITEH3RO™ Holder Sizes

Description	SKU	Size	Impact Wrench
1/2" Square Holder	USH12	1/2"	1/2" Impact Wrench
3/4" Square Holder	USH34	3/4"	3/4" Impact Wrench

Turn your Impact Wrench into a multipurpose metal working machine.

1. Connect

Connect the holder to the Impact Wrench

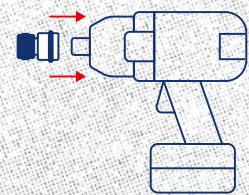

2. Click

Insert the tool

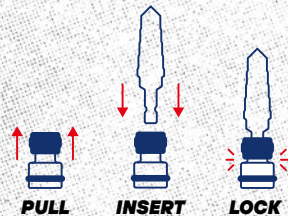
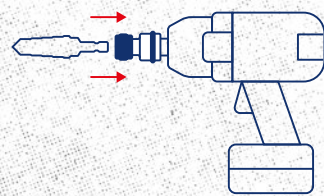

3. GO

Start DRILLING!

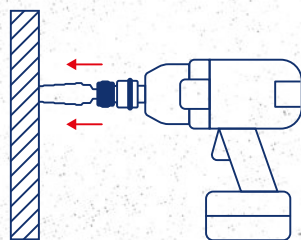

SITEH3RO™: Car Reamer

SITEH3RO™

CAR REAMER

- Align, clean out and expand holes on site with your impact wrench and SITEH3RO™
- High performance coating for up to 75% longer tool life
- Available in 13 major diameter sizes
- Suitable for use in standard 3-jaw drill chucks
- Smooth, easy cut

Spiral Flute for Faster Cuts

SITEH3RO™ Coating

Safety Collar

7/16" Hex Impact Shank

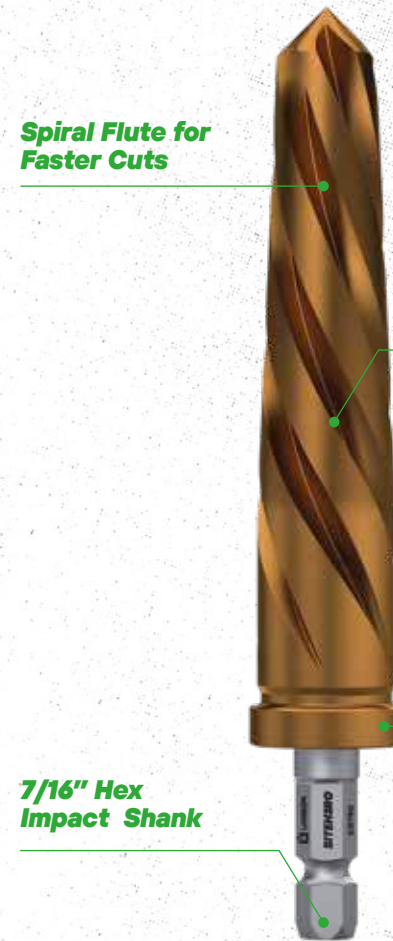

CAR REAMER Sizes

SKU	Diameter	Shank
CR312	5/16"	7/16" Hex Impact Shank
CR375	3/8"	
CR437	7/16"	
CR500	1/2"	
CR562	9/16"	
CR625	5/8"	
CR687	11/16"	
CR750	3/4"	
CR812	13/16"	
CR875	7/8"	
CR937	15/16"	
CR1000	1"	
CR1062	1-1/16"	

CAR REAMER Kits

SKU	Size Range	Kit
SHUCR1	3/8", 1/2", 5/8", 3/4"	4 Piece Kit
SHUCR2	3/8", 1/2", 5/8", 3/4", 7/8", 1"	6 Piece Kit
SHUCR3	5/16", 3/8", 7/16", 1/2", 9/16", 5/8", 11/16", 3/4", 13/16", 7/8", 15/16", 1", 1-1/16"	13 Piece Kit

75%
Longer life with SITEH3RO™ coating

Suitable for 1/2" and 3/4" Impact Wrenches (holder dependent)

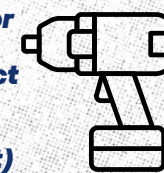

ALIGN HOLES

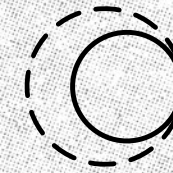

EXPAND HOLES

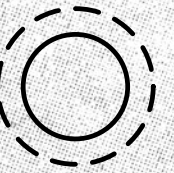

STEP REAMER



- Expand and clean out holes with your Impact Wrench
- 3 tools allow you to expand and clean out holes across 15 sizes from 5/16" to 1-1/16" in up to 1/2" thick material
- Ideal for expanding holes and available in all major bolt sizes
- High performance coating, providing up to 75% longer tool life
- Suitable for use in standard 3-jaw drill chucks

STEP REAMER Sizes

SKU	Diameter	Shank
SR312562	5/16" to 9/16"	7/16" Hex Impact Shank
SR562812	9/16" to 13/16"	
SR8121062	13/16" to 1-1/16"	

All STEP REAMERS include 5 steps with 1/2" Step Lengths.

STEP REAMER Kit

SKU	Size Range	Kit
SHUSR1	5/16" to 9/16" 9/16" to 13/16" 13/16" to 1-1/16"	3 Piece Kit

75%
Longer life with SITEH3RO™ coating

Suitable for 1/2" and 3/4" Impact Wrenches (holder dependent)

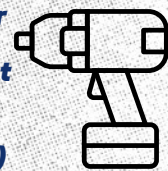

NEW HOLES



EXPAND HOLES

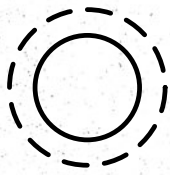

STEP DRILL

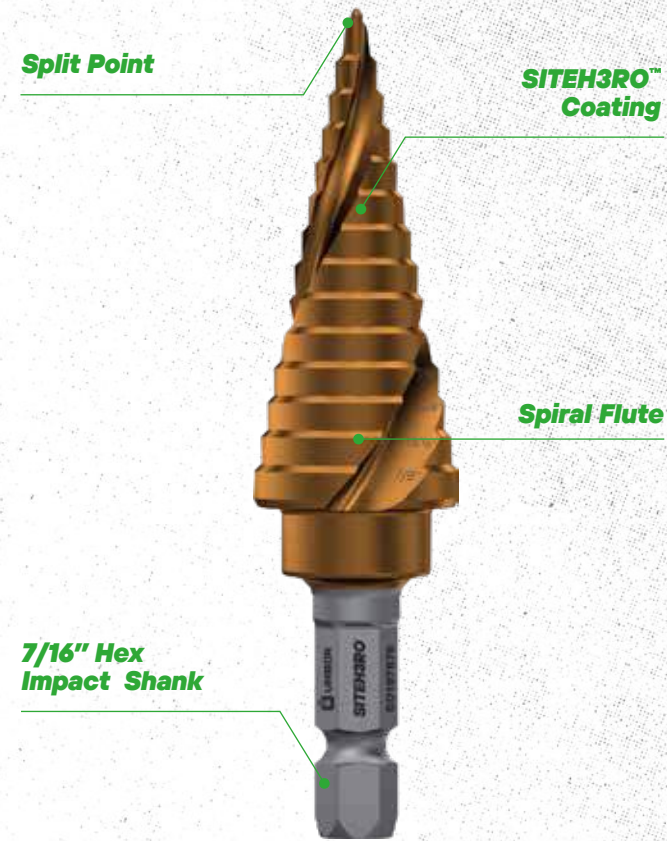

- Drill new holes and expand thin gauge material with an Impact Wrench and SITEH3RO™
- Utilize in SITEH3RO™ holders for Impact Wrenches or any standard drill chuck
- Holes from 1/8" to 1-3/8" in diameter
- High performance coating for up to 75% longer tool life
- Suitable for use in standard 3-jaw drill chucks

STEP DRILL Sizes

SKU	Diameter	Shank
SD125500	1/8" to 1/2"	7/16" Hex Impact Shank
SD187875	3/16" to 7/8"	
SD2501375	1/4" to 1-3/8"	

All STEP DRILLS include a spiral flute with 118° point.

STEP DRILL Kit

SKU	Size Range	Kit
SHUSD1	1/8" to 1/2" 3/16" to 7/8" 1/4" to 1-3/8"	3 Piece Kit

75%
Longer life with SITEH3RO™ coating

Suitable for 1/2" and 3/4" Impact Wrenches (holder dependent)

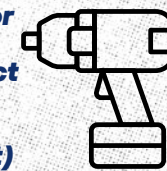

NEW HOLES

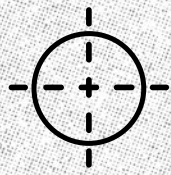

EXPAND HOLES

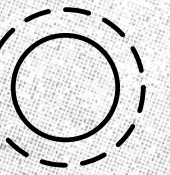

TAPS

Spiral Point Machine Tap



SITEH3RO™ Coating

7/16" Hex Impact Shank

- **Spiral Point Machine Tap : One Tap Solution**
- **Suitable for use in standard 3-jaw drill chucks**
- **Thread holes with your Impact Wrench – up to 20 X faster than hand tapping**
- **High performance coating for up to 75% longer tool life**
- **Thread holes from 1/4" to 1" UNC**
- **Tap holes in material up to 1/2" thick**
- **Available in 8 major sizes**

TAP Sizes

SKU	Diameter	Shank
TP250	1/4" UNC	7/16" Hex Impact Shank
TP312	5/16" UNC	
TP375	3/8" UNC	
TP500	1/2" UNC	
TP625	5/8" UNC	
TP750	3/4" UNC	
TP875	7/8" UNC	
TP1000	1" UNC	

TAP Kits

SKU	Size Range	Kit
SHUTP1	1/4", 5/16", 3/8", 1/2", 5/8"	5 Piece Kit
SHUTP2	1/2", 5/8", 3/4", 1"	4 Piece Kit
SHUTP3	1/4", 5/16", 3/8", 1/2", 5/8", 3/4", 7/8", 1"	8 Piece Kit

75%
Longer life with SITEH3RO™ coating

Suitable for 1/2" and 3/4" Impact Wrenches (holder dependent)

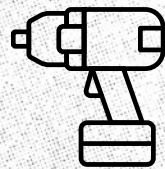

THREAD HOLES

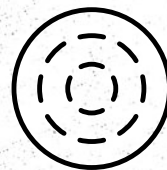

KITS



SITEH3RO™ Ultimate Kit

SKU	Size Range	Kit	Qty
SHU1	1/8" - 1/2" & 3/16" - 7/8" & 1/4" - 1-3/8"	Step Drills	3
	5/16"-9/16" & 9/16" - 13/16" & 13/16" to 1-1/16"	Step Reamers	3
	1/2" & 5/8" & 3/4"	Car Reamers	3
	1/4" & 3/8" & 1/2"	Taps	3

75%
Longer life with SITEH3RO™ coating

Suitable for 1/2" and 3/4" Impact Wrenches (holder dependent)

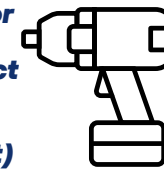

NEW HOLES



EXPAND HOLES



THREAD HOLES



ALIGN HOLES

CAR REAMER Kits

SKU	Size Range	Kit
SHUCR1	3/8", 1/2", 5/8", 3/4"	4 Piece Kit
SHUCR2	3/8", 1/2", 5/8", 3/4", 7/8", 1"	6 Piece Kit
SHUCR3	5/16", 3/8", 7/16", 1/2", 9/16", 5/8", 11/16", 3/4", 13/16", 7/8", 15/16", 1", 1-1/16"	13 Piece Kit

STEP REAMER Kit

SKU	Size Range	Kit
SHUSR1	5/16" to 9/16" 9/16" to 13/16" 13/16" to 1-1/16"	3 Piece Kit

STEP DRILL Kit

SKU	Size Range	Kit
SHUSD1	1/8" to 1/2" 3/16" to 7/8" 1/4" to 1-3/8"	3 Piece Kit

TAP Kits









SKU	Size Range	Kit
SHUTP1	1/4", 5/16", 3/8", 1/2", 5/8"	5 Piece Kit
SHUTP2	1/2", 5/8", 3/4", 1"	4 Piece Kit
SHUTP3	1/4", 5/16", 3/8", 1/2", 5/8", 3/4", 7/8", 1"	8 Piece Kit

POWER TOOL Accessories - Choosing the RIGHT tool for the RIGHT job.

POWER TOOL ACCESSORY SELECTION CHART

UNIBOR offers a wider range of **POWERTOOL ACCESSORIES** focussed on metal working. Use this guide to identify what the correct tool for your application is for the material, thickness and power tool you are using.

 Align
  New
  Expand

Product	Max Dia.	Application			Material Thickness					Material Type			Shank	
		Align	New	Expand	1/8"	3/16"	1/4"	1/2"	1"	Plastics	Steel <900N	Stainless Steel	3 Flats	1/4" Hex Impact
					—	—	—	—	—					

STEP DRILLS - MULTICUT

Standard		✓	✓	✓	✓	✗	✗	✗	✗	✓	✓	✗	✓	✗
Impact	1-3/8"	✓	✓	✓	✓	✗	✗	✗	✗	✓	✓	✗	✗	✓
Impact Pro		✓	✓	✓	✓	✗	✗	✗	✗	✓	✓	✓	✗	✓

CONE DRILLS - CONECUT

Standard	2-1/16"	✓	✓	✓	✓	✗	✗	✗	✗	✓	✓	✗	✓	✗
Impact	1-3/16"	✓	✓	✓	✓	✗	✗	✗	✗	✓	✓	✗	✗	✓

HOLE SAWS

TCT Speed Cut	1-3/8"	✗	✓	✗	✗	✓	✗	✗	✗	✓	✓	✓	✗	✓
TCT Long Cut	4-1/2"	✗	✓	✗	✗	✓	✓	✓	✓*	✓	✓	✓	✓	✗

REAMERS

Car Reamers	1-1/16"	✓	✗	✓	✗	✗	✗	✓	✓	✓	✓	✓	✓	✗
Step Reamers		✗	✓	✓	✗	✗	✗	✓	✓	✗	✓	✓	✓	✗

*1" possible when used in a magnetic drill.

STEP DRILLS

- Designed for HVAC, electrical and sheet metal work
- Dual flute and spiral technologies available
- The most comprehensive step drill offering available in North America
- Featuring split point technology, for faster starts and no wander
- Made in England



1/8" to 1-3/8"
Diameter

1/8" Depth

SPLIT POINT

2x

Longer LIFE with High Speed Steel and Cobalt

Straight and Spiral Flute Options

MULTIPLE Shank Options



Available as individuals and in kits

MULTICUT STANDARD STEP DRILL

Available in kits. See pages 66 and 67 for more information.

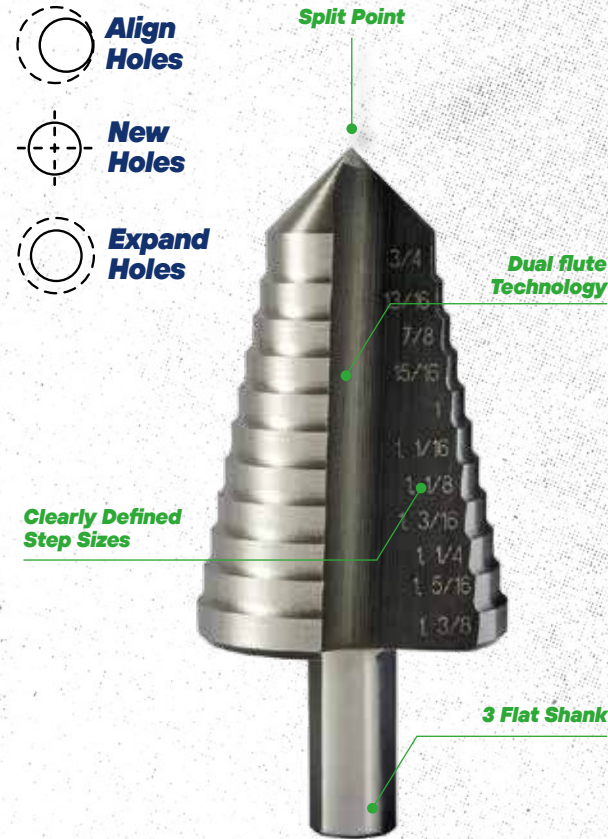

- Dual Flute Technology
- Split point design for 50% faster starts
- Made from High Grade M2 High Speed Steel
- BLUE MAX surface treated to increase tool life
- Featuring a 3-flat non-slip shank design

Knock Out Sizes

Step Drill Code	SKU	Size Range	Shank
#9	06X3/4KO	7/8" - 1-1/8"	3/8"
#5	06X1KO	7/8" - 1-3/8"	

MULTICUT Standard Sizes

Step Drill Code	SKU	Size Range	Shank
#1	06X1E	1/8" - 1/2"	1/4"
#3	06X2E	1/4" - 3/4"	3/8"
#6	06X4E	1/4" - 1-3/8"	
#4	06X5E	3/16" - 7/8"	1/4"
#2	06X7E	3/16" - 1/2"	

MULTICUT Standard Step Drill Kits

Kit	Part No.	SKU	Size Range	Shank
3 Piece Kit	06X1E, 06X2E, 06X7E	MK1STD	1/8"-1/2", 1/4"-3/4", 3/16"-1/2"	3-Flat
	06X1E, 06X6E, 06X3/4KO, 06X1KO		1/8"-1/2", 3/16"-7/8", 7/8"-1-1/8", 7/8"-1-3/8"	

Suitable for Drilling:



SPLIT POINT

COMBI Ready

STRAIGHT Flute

Surface TREATED

MAX Depth 1/8"

3 FLAT SHANK

MULTICUT IMPACT STEP DRILL

Available in kits. See pages 66 and 67 for more information.

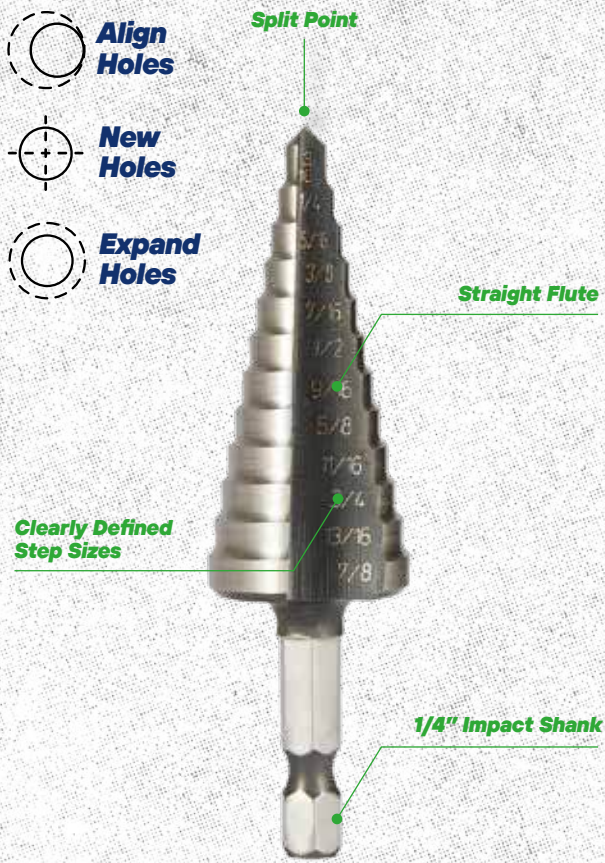

- Dual Flute Technology
- Made from High Grade M2 High Speed Steel
- Split point design for 50% faster starts
- Non-Slip point for easier starts
- Blue Max surface treated to increase tool life
- 1/4" impact shank, ready for use in your impact driver

Knock Out Size

Step Drill Code	SKU	Size Range	Shank
#9	06X3/4KOIMP	7/8" - 1-1/8"	1/4" Impact

MULTICUT Impact Sizes

Step Drill Code	SKU	Size Range	Shank
#1	06X1EIMP	1/8" - 1/2"	1/4" Impact
#3	06X2EIMP	1/4" - 3/4"	
#6	06S4EIMP	1/4" - 1-3/8"	
#4	06X5EIMP	3/16" - 7/8"	
#2	06X7EIMP	3/16" - 1/2"	

MULTICUT Impact Step Drill Kit

Kit	Part No.	SKU	Size Range	Shank
3 Piece Impact Shank Kit	06X1EIMP, 06X2EIMP, 06X7EIMP	MK2IMP	1/8"-1/2", 1/4"-3/4", 3/16"-1/2"	1/4" Impact

Suitable for Drilling:



MULTICUT IMPACT PRO STEP DRILL

Available in kits. See pages 66 and 67 for more information.

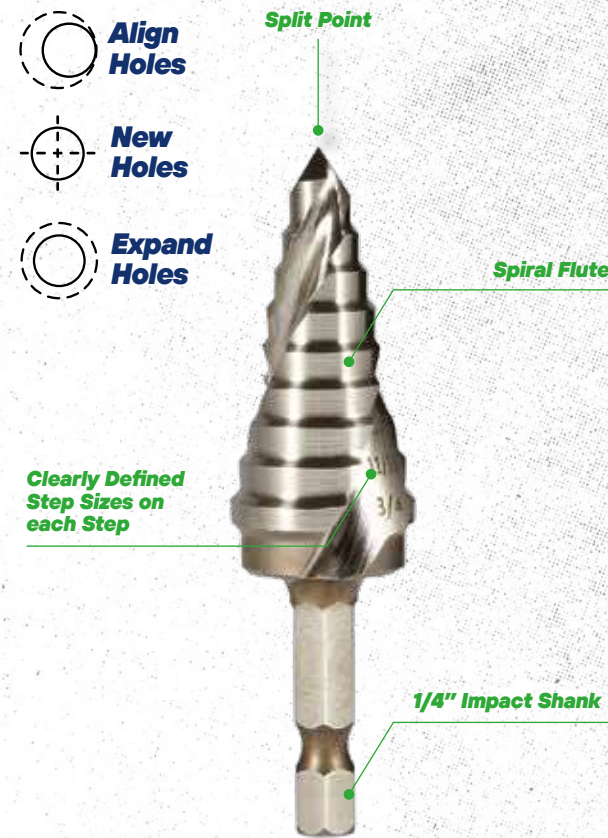

- Spiral flute technology for up to 30% faster cutting speed
- Split point design for 50% faster starts
- Made from M42 Cobalt for increased durability
- Ideal for stainless steel
- 1/4" impact shank, ready for use in your impact driver

Knock Out Sizes

Step Drill Code	SKU	Size Range	Shank	Flute
#9	06S3/4KOIMP	7/8" - 1-1/8"	1/4" Impact	Spiral
#5	06S1KOIMP	7/8" - 1-3/8"		

MULTICUT Impact Pro Sizes

Step Drill Code	SKU	Size Range	Shank	Flute
#1	06S1EIMP	1/8" - 1/2"	1/4" Impact	Spiral
#3	06S2EIMP	1/4" - 3/4"		
#6	06S4EIMP	1/4" - 1-3/8"		
#4	06S5EIMP	3/16" - 7/8"		
#2	06S7EIMP	3/16" - 1/2"		

MULTICUT Impact Pro Step Drill Kits

Kit	Part No.	SKU	Size Range	Shank
3 Piece Impact Spiral Cobalt Kit	06S1EIMP, 06S2EIMP, 06S7EIMP	MK3SPIRALIMP	1/8"-1/2", 1/4"-3/4", 3/16"-1/2"	1/4" Impact
4 Piece Impact Spiral Electrical & HVAC Kit	06S1EIMP, 06S6EIMP, 06S3/4KOIMP, 06S1KOIMP	MK5SPIRALIMP ELECTRICAL	1/8"-1/2", 3/16"-7/8", 7/8"-1-1/8", 7/8"-1-3/8"	1/4" Impact

Suitable for Drilling:

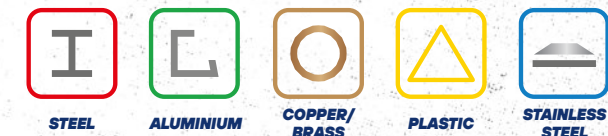

CONE DRILLS

- Ideal for HVAC and electrical installations
- Designed for material up to 14 gauge thick
- Available as 3-flat shank and 1/4" impact ready shank
- Ideal for the best finish on thin gauge materials
- Non-slip point for easier starts
- Made in England



Available as individuals and in kits



1/8" to 1-3/16" Diameter



1/8" Depth



3 FLAT SHANK



IMPACT Driver Ready

50% LONGER LIFE with M2 High Speed STEEL



Surface TREATED



3/4" SHANK



COMBI Drill Ready

CONECUT STANDARD CONE DRILL

Available in kits. See pages 66 and 67 for more information.

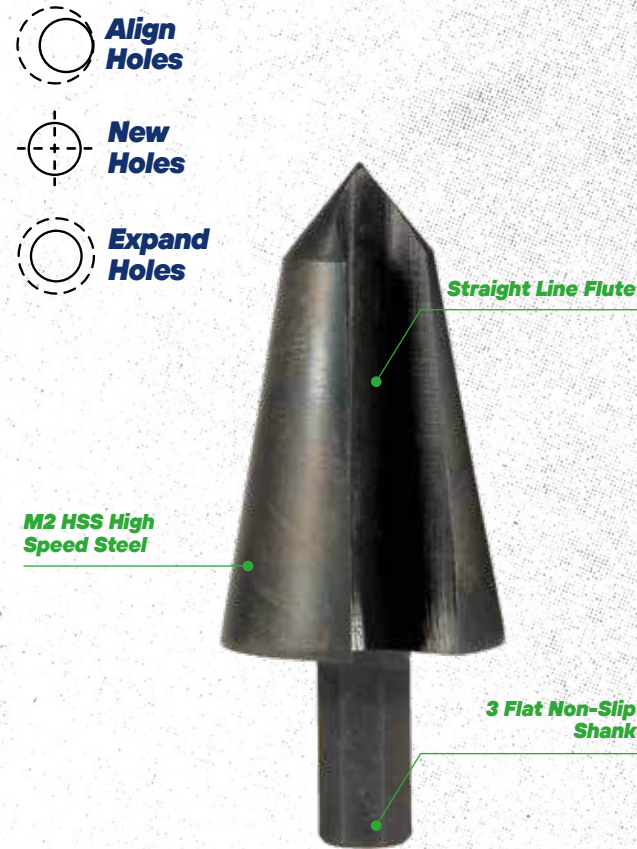

- Made from High Grade M2 High Speed Steel
- Non-Slip Point for easier starts and better concentricity
- Treated with blue steam tempering to maximize tool life

CONECUT Standard Sizes

SKU	Size Range	Shank	Shank Type
O2X0HTI	1/8" - 9/16"	1/4"	3 Flat
O2X1HTI	1/4" - 13/16"	3/8"	
O2X2HTI	5/8" - 1-3/16"	3/8"	
O2X3HTI	1" - 1-5/8"	3/8"	
O2X4HTI	1 1/2" - 2-1/16"	1/2"	
O2X830	5/16" - 1-3/16"	3/8"	

Suitable for Drilling:



CONECUT Standard Cone Drill Kits

Kit	Part No.	SKU	Size Range	Shank
3 Piece Kit: 3 Flat Shank	O2X0HTI, O2X1HTI, O2X2HTI	Conekit1	1/8"-9/16", 1/4"-13/16", 5/8"-1-3/16"	3 Flat



Surface TREATED



COMBI Ready

50% LONGER LIFE with M2 High Speed STEEL

M2 HSS High Speed STEEL





MAX Depth 1/8"



3 FLAT SHANK

CONECUT IMPACT CONE DRILL

Available in kits.
See pages 66
and 67 for more
information.

-  Align Holes
-  New Holes
-  Expand Holes

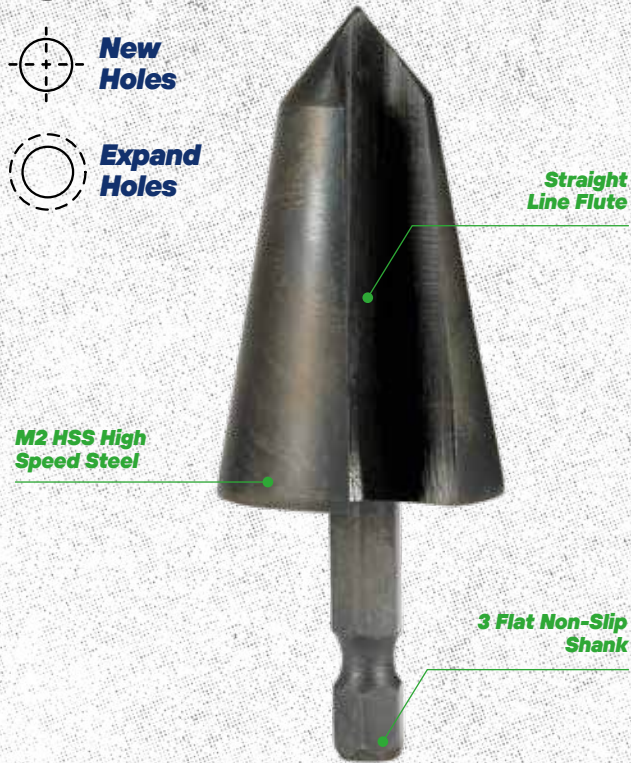

- 1/4" impact shank ideal for use in impact drivers & standard drill chucks
- Made from High Grade M2 High Speed Steel
- Non-Slip Point for easier starts and better concentricity
- Treated with blue steam tempering to maximize tool life

CONECUT Impact Sizes

SKU	Size Range	Shank	Shank Type
02X0HTIIMP	1/8" - 9/16"	1/4"	Impact
02X1HTIIMP	1/4" - 13/16"		
02X2HTIIMP	5/8" - 1-3/16"		

CONECUT Impact Cone Drill Kit

Kit	Part No.	SKU	Size Range	Shank
3 Piece Kit: 1/4" Impact Shank	02X0HTIIMP, 02X1HTIIMP, 02X2HTIIMP	Conekit2IMP	1/8"-9/16", 1/4"-13/16", 5/8"-1-3/16"	1/4" Impact

Suitable for Drilling:





**BLUE
MAX**
 Surface
TREATED



**IMPACT
Ready**

50%
 LONGER LIFE with
M2 High Speed
STEEL

M2 HSS
 High Speed
STEEL

**MAX
Depth 1/8"**

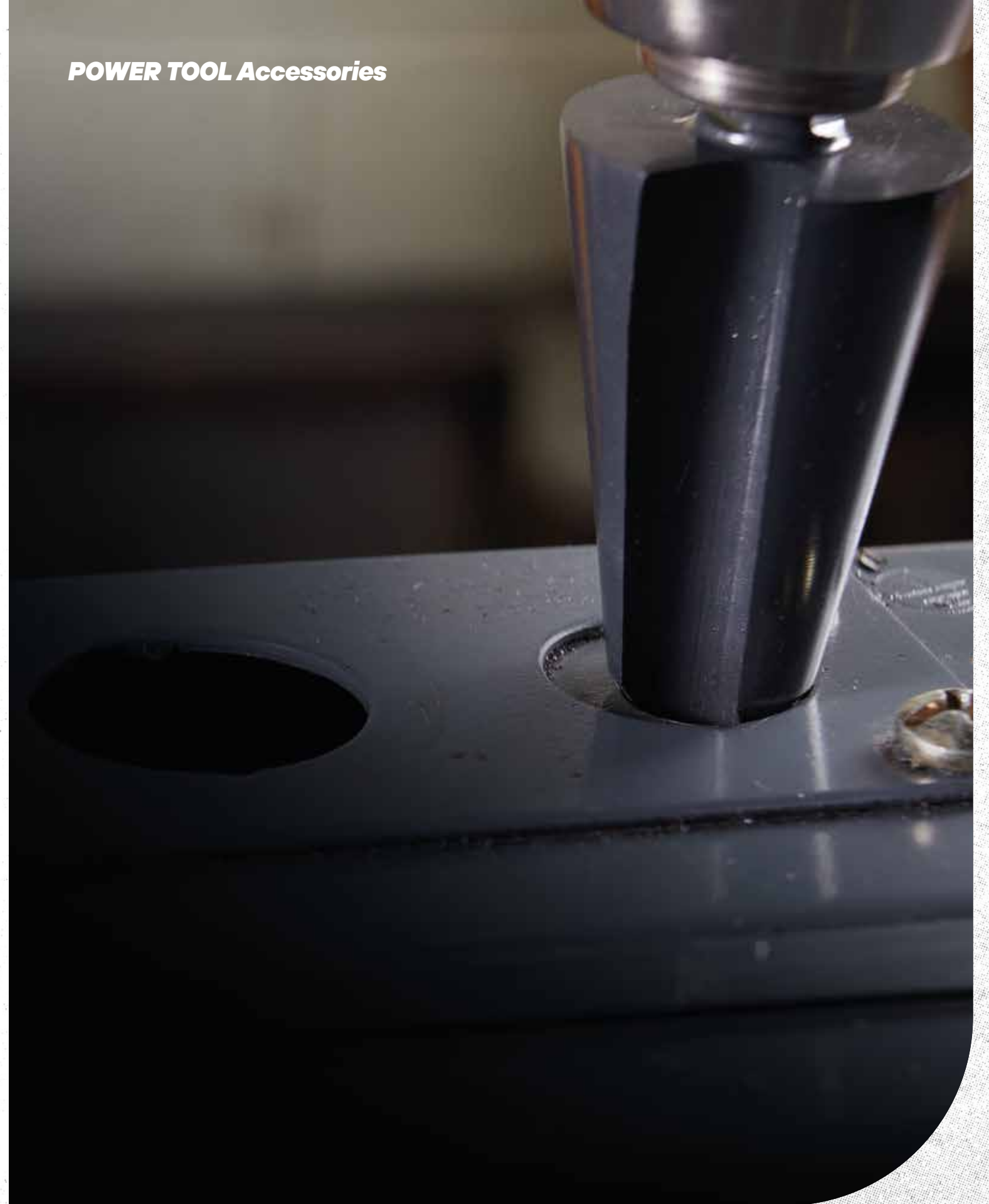
**1/4" IMPACT
SHANK**



TCT HOLESAWS

Our range of TCT Holesaws drill up to 30% Faster and last 10X longer than bi-metal holesaws or twist drills.



Available as individuals and in kits



9/16" to 4-1/2" Diameter



3/16" to 1" Depth



IMPACT Driver Ready

TCT

Tungsten Carbide Teeth cut faster and last longer.



MULTIPLE Shank Options



COMBI Drill Ready



TCT SPEEDCUT HOLESAW



- Ideal for thin gauge stainless steel, sheet metal in HVAC and electrical installations
- Impact shank ready for use in both impact drivers and combi-drills
- Spring loaded and supplied with arbor and drill bit as standard
- Available from 9/16" to 1-3/8" diameter, drilling up to 3/16" thick materials

TCT SPEEDCUT Sizes

Diameter	SKU	Diameter	SKU
9/16"	28118	1"	28132
5/8"	28120	1-1/16"	28134
11/16"	28122	1-1/8"	28136
3/4"	28124	1-3/16"	28138
13/16"	28126	1-1/4"	28140
7/8"	28128	1-5/16"	28142
15/16"	28130	1-3/8"	28144

Spare Drills and Springs

SKU	Description
RD43186	Centre Drill
RD43187	Spring

Suitable for Drilling:

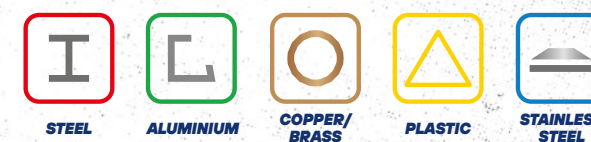



Spring LOADED



COMBI Ready



IMPACT Driver Ready



MAX Dia 1-3/8"



MAX Depth 3/16"



1/4" IMPACT SHANK



TCT LONGCUT HOLESAW

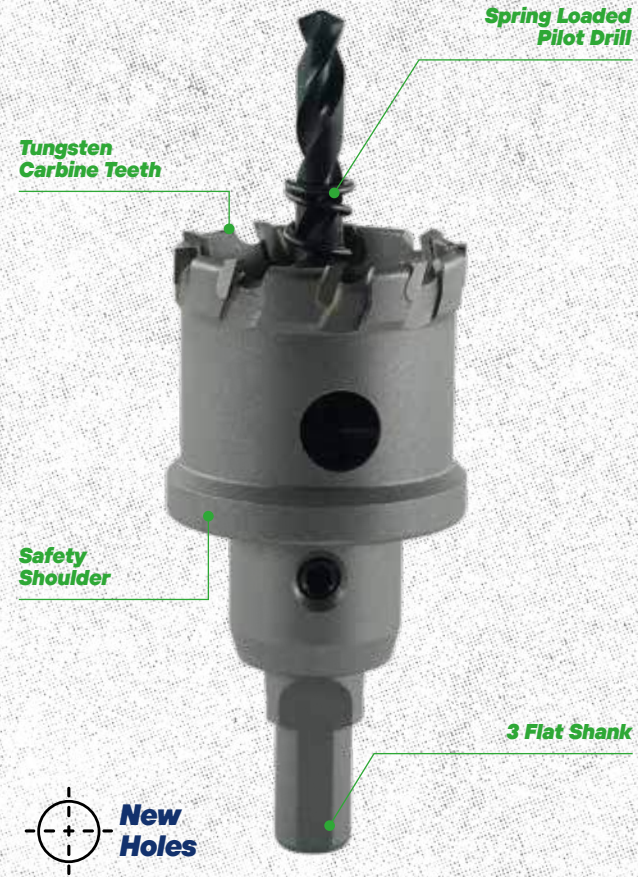

Suitable for Drilling:



Spring LOADED

COMBI Ready

SAFETY Shoulder

MAX Dia 4-1/2"

MAX Depth 1"

3 FLAT SHANK

- Ideal for thicker gauge material in steel girders and construction steel up to 1" depth of cut
- 3-Flat non-slip shank for use in drill presses and combi-drills
- Spring loaded for optimal waste ejection
- Available from 9/16" to 4-1/2" diameter, drilling up to 1" thick materials

TCT LONGCUT Sizes

Diameter	SKU	Diameter	SKU
9/16"	28218	1-3/4"	28256
5/8"	28220	1-13/16"	28258
11/16"	28222	1-7/8"	28260
3/4"	28224	1-15/16"	28262
13/16"	28226	2"	28264
7/8"	28228	2-1/8"	28268
15/16"	28230	2-1/4"	28272
1"	28232	2-3/8"	28276
1-1/16"	28234	2-1/2"	28280
1-1/8"	28236	2-9/16"	28282
1-3/16"	28238	2-5/8"	28284
1-1/4"	28240	2-3/4"	28288
1-5/16"	28242	2-7/8"	28292
1-3/8"	28244	3"	28296
1-7/16"	28246	3-1/4"	282hs3.1/4
1-1/2"	28248	3-1/2"	282hs3.1/2
1-9/16"	28250	4"	282hs4
1-5/8"	28252	4-1/4"	282hs4.1/4
1-11/16"	28254	4-1/2"	282hs4.1/4

Spare Drills and Springs

SKU	Description
RD40095	Drill
RD40094	Spring



REAMERS

OUR INDUSTRY STANDARD RANGE OF CAR AND STEP REAMERS ARE SUITABLE FOR DRILLING STEEL, ALUMINIUM, BRASS & PLASTIC



Available as individuals and in kits



CAR REAMERS

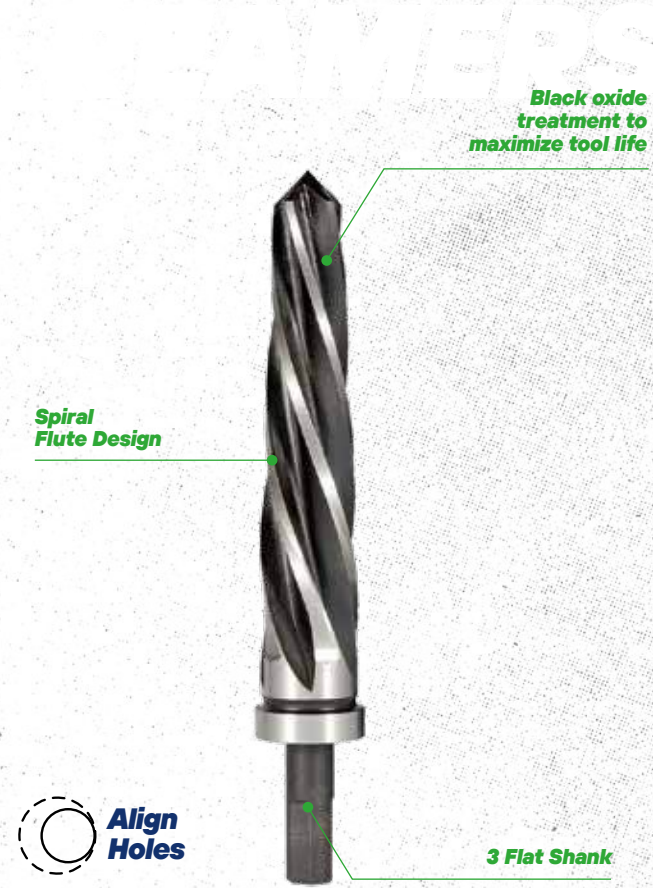

Suitable for Drilling:

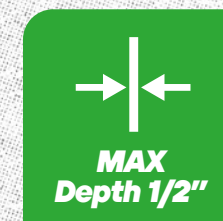

Available in kits. See pages 66 and 67 for more information.

- Align, expand and clean out holes
- Advanced spiral flute design for faster cutting and enhanced tool life
- Safety shoulder featured for optimal working safety
- BLACK MAX treated for increased tool life

CAR REAMER Sizes

SKU	Max Dia.	Min Dia.	Shank Size	Flute Length	Overall Length
CR0516	5/16"				
CR038	3/8"	3/16"	3/8"	3"	5"
CR0716	7/16"	7/32"	7/16"	3-5/16"	5-1/4"
CR012	1/2"	1/4"		4"	5-15/16"
CR0916	9/16"	5/16"			
CR058	5/8"			4-5/8"	6-9/16"
CR01116	11/16"	11/32"			
CR034	3/4"	15/32"	1/2"	5"	7"
CR01316	13/16"	17/32"			
CR078	7/8"	19/32"			
CR01516	15/16"	21/32"		5-7/16"	7-1/4"
CR01	1"	23/32"			
CR1-116	1-1/16"	25/32"			

CAR REAMER Kit

Kit Code	SKU	Max Dia.	Min Dia.	Shank Size	Flute Length	Overall Length
M09700FKIT3	CR012	1/2"	1/4"		4"	5-15/16"
	CR058	5/8"	5/16"	1/2"	4-5/8"	6-9/16"
	CR034	3/4"	15/32"		5"	7"
M09700FSET	CR038	3/8"	3/16"	3/8"	3"	5"
	CR012	1/2"	1/4"		4"	5-15/16"
	CR058	5/8"	5/16"		4-5/8"	6-9/16"
	CR034	3/4"	15/32"	1/2"	5"	7"
	CR078	7/8"	19/32"		5-7/16"	7-1/4"
	CR01	1"	23/32"		5-7/16"	7-1/4"



STEP REAMERS

Available in kits.
See pages 66
and 67 for more
information.



- Expand and clear out multiple hole sizes with 3 tools and 15 sizes
- Ideal for ironworkers on site, working with steel beams
- Available individually and as kits

STEP REAMER Sizes

SKU	Max Depth	Step 1	Step 2	Step 3	Step 4	Step 5
19X312E5562	1/2"	5/16"	3/8"	7/16"	1/2"	9/16"
19X562E5812		9/16"	5/8"	11/16"	3/4"	13/16"
19X812E51062		13/16"	7/8"	15/16"	1"	1 1/16"

STEP REAMER Kit

Kit Code	SKU	Max Depth	Step 1	Step 2	Step 3	Step 4	Step 5
19K02	19X312E5562	1/2"	5/16"	3/8"	7/16"	1/2"	9/16"
	19X562E5812		9/16"	5/8"	11/16"	3/4"	13/16"
	19X812E51062		13/16"	7/8"	15/16"	1"	1 1/16"



Suitable for Drilling:

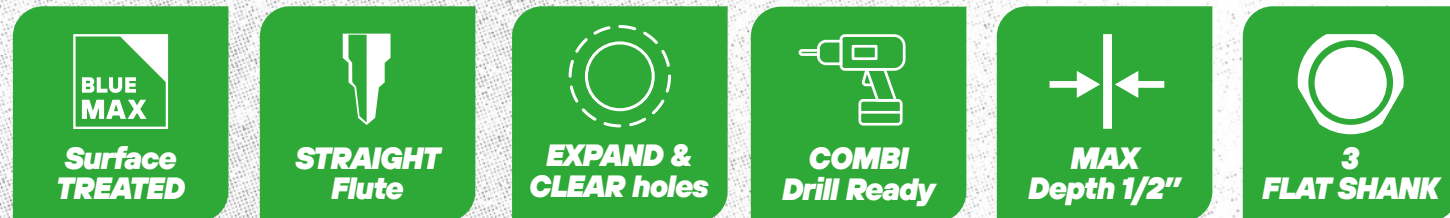

POWER TOOL ACCESSORY KITS



MULTICUT Standard Step Drill Kits

Kit	Part No.	SKU	Size Range	Shank
3 Piece Kit	06X1E, 06X2E, 06X7E	MK1STD	1/8"-1/2", 1/4"-3/4", 3/16"-1/2"	3-Flat
4 Piece Electrical & HVAC Kit	06X1E, 06X6E, 06X3/4KO, 06X1KO	MK4ELECTRICAL	1/8"-1/2", 3/16"-7/8", 7/8"-1-1/8", 7/8"-1-3/8"	3-Flat

MULTICUT Impact Step Drill Kit

Kit	Part No.	SKU	Size Range	Shank
3 Piece Impact Shank Kit	06X1EIMP, 06X2EIMP, 06X7EIMP	MK2IMP	1/8"-1/2", 1/4"-3/4", 3/16"-1/2"	1/4" Impact

MULTICUT Impact Pro Step Drill Kits

Kit	Part No.	SKU	Size Range	Shank
3 Piece Impact Spiral Cobalt Kit	06S1EIMPCO, 06S2EIMPCO, 06S7EIMPCO	MK3SPIRALIMP	1/8"-1/2", 1/4"-3/4", 3/16"-1/2"	1/4" Impact
4 Piece Impact Spiral Electrical & HVAC Kit	06S1EIMPCO, 06S6EIMPCO, 06S3/4KOIMP-CO, 06S1KO-IMP-CO	MK5SPIRAIMP ELECTRICAL	1/8"-1/2", 3/16"-7/8", 7/8"-1-1/8", 7/8"-1-3/8"	1/4" Impact



CAR REAMER Kits

Kit Code	SKU	Max Dia.	Min Dia.	Shank Size	Flute Length	Overall Length
M09700FKIT3	CR012	1/2"	1/4"	1/2"	4"	5-15/16"
	CR058	5/8"	5/16"		4-5/8"	6-9/16"
	CR034	3/4"	15/32"		5"	7"
M09700FSET	CR038	3/8"	3/16"	3/8"	3"	5"
	CR012	1/2"	1/4"	1/2"	4"	5-15/16"
	CR058	5/8"	5/16"		4-5/8"	6-9/16"
	CR034	3/4"	15/32"		5"	7"
	CR078	7/8"	19/32"		5-7/16"	7-1/4"
	CR01	1"	23/32"		5-7/16"	7-1/4"



STEP REAMER Kit

Kit Code	SKU	Max Depth	Step 1	Step 2	Step 3	Step 4	Step 5
19K02	19X312E5562	1/2"	5/16"	3/8"	7/16"	1/2"	9/16"
	19X562E5812		9/16"	5/8"	11/16"	3/4"	13/16"
	19X812E51062		13/16"	7/8"	15/16"	1"	1 1/16"



TCT LONGCUT HOLESAW Kit

Kit	Part No.	SKU	Size Range
Unibor 5 Piece Electrical Kit	28228, 28236, 28244, 28256, 28264	ElecKit01	7/8", 1-1/8", 1-3/8", 1-3/4", 2"
Unibor 5 Piece Fabricator Kit	28218, 28222, 28226, 28230, 28234	FabKit01	9/16", 11/16", 13/16", 15/16", 1-1/16"

CONECUT Standard Cone Drill Kits

Kit	Part No.	SKU	Size Range	Shank
3 Piece Kit: 3 Flat Shank	02X0HTI, 02X1HTI, 02X2HTI	Conekit1	1/8"-9/16", 1/4"-13/16", 5/8"-1-3/16"	3 Flat

CONECUT Impact Cone Drill Kit

Kit	Part No.	SKU	Size Range	Shank
3 Piece Kit: 1/4" Impact Shank	02X0HTIIMP, 02X1HTIIMP, 02X2HTIIMP	Conekit2IMP	1/8"-9/16", 1/4"-13/16", 5/8"-1-3/16"	1/4" Impact





UNIBOR™

BUILT For Metal.™

EMAIL: USA@UNIBOR.COM

TEL: 800-969-9644

WEB: UNIBOR.COM

**UNIBOR USA,
77 EISENHOWER LANE S.
LOMBARD, IL 60148**

Universal Drilling and Cutting Equipment is constantly developing new products, and refining and improving the existing product range. Consequently, we reserve the right to change without notice the details and specifications shown in this document. **WARRANTY:** Universal Drilling Inc. warrants its portable magnetic drills for one (1) year from the date of purchase. This warranty covers defects due to faulty material or workmanship. Warranty is voided if unauthorized repair work has been attempted or machinery has been used in away not intended by design. Warranty is also voided if machine is inoperable for reasons not resulting from defects in material or workmanship. Universal Drilling reserves the right to inspect machinery to determine cause of claim and whether covered under warranty. No other warranty is implied or sanctioned. Universal Drilling disclaims any implied warranty beyond the original warranty period of 12 months and shall not be liable for any incidental or consequential damages. Some of the products shown herein are protected under U.K., U.S. and International patents. **DISTRIBUTED BY: ©2024 Universal Drilling & Cutting ALL RIGHTS RESERVED.**

