

# HUW150 Hydrobor Assembly & Parts List

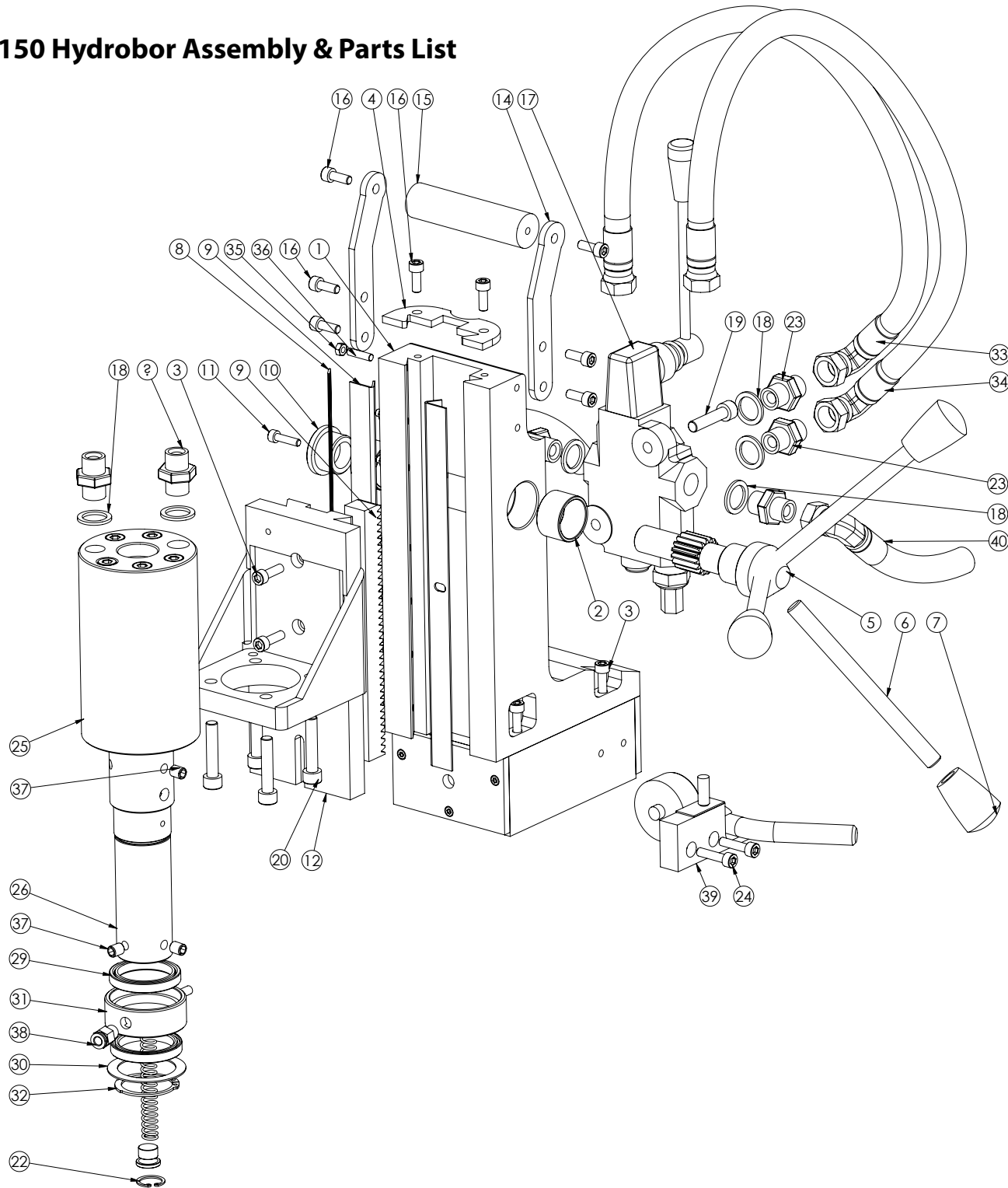

ITEM NO.	PART NUMBER	DESCRIPTION	QTY.
1	HYD150	HUW150 BODY	1
2	M0081	PINION BUSH	2
3	SC620CAP	M6x20Lg CAPSCREW	7
4	10084z	TOP PLATE	1
5	M0042	PINION LARGE ZINC	1
6	10081	HANDLE 12mm SHORT	3
7	10082	HANDLE KNOB 12mm	3
8	20389	G.F.S	1
9	60100A	BRASS STRIP	2
10	M0072	PINION END CAP DEEP ZINC	1
11	SC520CAP	M5x20Lg CAPSCREW	1
12	RT201	HUW HYDRAULIC CRADLE	1
13	10215	RACK (MINIBOR)	1
14	10033	HUW HANDLE SIDE BRACKET	2
15	handle	HUW CARRY HANDLE	1
16	SC616CAP	M6x16Lg CAPSCREW	8
17	valve	HYDRAULIC VALVE (EMERG STOP)	1
18	BS-38	3/8" BSP BONDED SEAL	6
19	SC835CAP	M8x35Lg CAPSCREW	2
20	SC840CAP	M8x40Lg CAPSCREW	4
21	spr101	ARBOR SPRING (MINIBOR)	1
22	CCP-19	19mm INTERNAL CIRCLIP	1
23	HYD014	3/8" x 3/8" MALE/MALE COUPLING	6
24	SC625CAP	M6x25 CAPSCREW	2
25	Compact200	HYDRAULIC MOTOR	1
26	Arboil10	HYDRAULIC DRILL ARBOR	1
27	SC830CAP	M8x30Lg CAPSCREW	1
28	SC825CAP	M8x25Lg CAPSCREW	4
29	RTB003-1	SHAFT SEAL	2
30	RT031	COOLANT RING WASHER	1
31	RT022	OIL RING	1
32	CCP-36	32mm EXTERNAL CIRCLIP	1
33	HYD012	HUW150.630x 3/8"R2/90 DEG FEM PIPE	1
34	HYD011	HUW150.700x 3/8"R2/90 DEG FEM PIPE	1
35	NUT-M5	M5 FULL NUT	7
36	SC5GRUB	M5x20Lg GRUBSCREW	7
37	SC810GRUB	M8x10Lg GRUBSCREW	4
38	50015A	1/4" BSP x 6mm PUSH FIT	1
39	HYD021	MAGNET ACTIVATION HANDLE	1
40	HYD013	HUW150.650x 3/8"R2/90 DEG FEM PIPE	2
41	10205	ARBOR EJECTION PLUG	1
42	NL0200	MAGNET	1