



UNIBOR™



E5000LP

Magnetic Drilling Machine



Contents

	Page
Intended Use	4
General Safety Rules	5
Information Plate Symbols	7
Specification	8
Operational Safety Procedures	9
Operating Instructions	10
Control Panel	11
Extension Cable Selection	12
Mounting Of Cutters	13
Troubleshooting	14
Wiring Diagram	15
Machine Parts	16
Pipe Adapter	19
Maintenance	20
Cutting Speed Selection	22
Warranty Statements	23

Part	Description	Quantity
RDF4030	4mm Hexagonal Wrench	2
RDF4031	Coolant Bottle	1
RDF4032	Ratchet Handle	1
RD4329	Safety Strap	1
RDF3005	Carbon Brush Set	1

Intended Use

The intended use of this magnetic drill is to drill holes in ferrous metals. The magnet is used to hold the drill in place whilst the drill is functioning. It is designed for use in fabrication, construction, railways, petrochemical and any other applications when drilling ferrous metal.

Any deviation from its intended use will not be covered by warranty.

General Safety Rules

WARNING! Read and understand all instructions. Failure to follow all instructions listed below, may result in electric shock, fire and/or serious personal injury.

SAVE THESE INSTRUCTIONS

Work Area

1. Keep your work area clean and well lit. Cluttered benches and dark areas invite accidents.
2. Do not operate power tools in explosive atmospheres, such as in the presence of flammable liquids, gases, or dust. Power tools create sparks which may ignite the dust or fumes.
3. Keep bystanders, children, and visitors away while operating a power tool. Distractions can cause you to lose control.

Electrical Safety

1. Grounded tools must be plugged into an outlet properly installed and grounded in accordance with all codes and ordinances. Never remove the grounding prong or modify the plug in any way. Do not use any adaptor plugs. Check with a qualified electrician if you are in doubt as to whether the outlet is properly grounded. If the tools should electrically malfunction or break down, grounding provides a low resistance path to carry electricity away from the user.
2. Avoid body contact with grounded surfaces such as pipes, radiators, ranges and refrigerators. There is an increased risk of electric shock if your body is grounded.
3. Don't expose power tools to rain or wet conditions. Water entering a power tool will increase the risk of electric shock.
4. Do not abuse the cord. Never use the cord to carry the tools or pull the plug from an outlet. Keep cord away from heat, oil, sharp edges or moving parts. Replace damaged cords immediately. Damaged cords increase the risk of electric shock.
5. When operating a power tool outside, use an outdoor extension cord marked "W-A" or "W". These cords are rated for outdoor use and reduce the risk of electric shock.

Personal Safety

1. Stay alert, watch what you are doing and use common sense when operating a power tool. Do not use tools when tired or under the influence of drugs, alcohol, or medication. A moment of inattention while operating power tools may result in serious personal injury.
2. Dress properly. Do not wear loose clothing or jewelry. Contain long hair. Keep your hair, clothing, and gloves away from moving parts. Loose clothes, jewelry or long hair can be caught in moving parts.
3. Avoid accidental starting. Be sure switch is off before plugging in. Carrying tools with your finger on the switch or plugging in tools that have the switch on invites accidents.
4. Remove adjusting keys or wrenches before turning the tool on. A wrench or a key that is left attached to a rotating part of the tool may result in personal injury.
5. Do not overreach. Keep proper footing and balance at all times. Proper footing and

General Safety Rules

Tool Use and Care

1. Use clamps or other practical way to secure and support the workpiece to a stable platform. Holding the work by hand or against your body is unstable and may lead to loss of control.
2. Do not force tool. Use the correct tool for your application. The correct tool will do the job better and safer at the rate in which it is designed.
3. Do not use tool if switch does not turn it on or off. Any tool that cannot be controlled with the switch is dangerous and must be repaired.
4. Disconnect the plug from the power source before making any adjustments, changing accessories, or storing the tool. Such preventive safety measures reduce the risk of starting the tool accidentally.
5. Store idle tools out of reach of children and other untrained persons. Tools are dangerous in the hands of untrained users.
6. Maintain tools with care. Keep cutting tools sharp and clean. Properly maintained tools, with sharp cutting edges are less likely to bind and are easier to control.
7. Check for misalignment or binding of moving parts, breakage of parts, and any other condition that may affect the tools operation. If damaged, have the tool serviced before using. Many accidents are caused by poorly maintained tools.
8. Use only accessories that are recommended by the manufacturer for your model. Accessories that may be suitable for one tool, may become hazardous when used on another tool.
9. Always use safety chain. Mounting can release.

SERVICE

1. Tools service must be performed only by qualified repair personnel. Service or maintenance performed by unqualified personnel could result in a risk of injury.
2. When servicing a tool, use only identical replacement parts. Follow instructions in the Maintenance section of this manual. Use of unauthorized parts or failure to follow Maintenance Instructions may create a risk of electric shock or injury.

Information Plate Symbols



1



2



3



4

1. Refer to the user manual for operational and safety issues with regards to this machine.
2. Dispose of the machine and electrical components correctly.
3. Eye protection must be worn when operating the machine.
4. Ear defenders must be worn when operating the machine.

Specification

Maximum hole cutting capacity in .2/.3C steel = 2-3/8" dia. x 3"

Arbordeep bore = MT2

Motor Unit	
Voltages	120V 50-60Hz
Normal Full Load	10A
Electro Magnet	0.53A
Size	7-9/16" long 3-1/4" wide
Holding Force at 20°C with 1" minimum plate thickness	2250lbs

The use on any material less than 1" thick will progressively reduce the magnetic performance. If possible, substitute material should be positioned under the magnet and work piece to equate to a suitable material thickness. If this is not possible, an alternative secure method of restraining the machine **MUST** be used.

Overall Dimensions	
Height - Maximum	7-3/64"
Width (inc Capstan Fitting)	3-15/16"
Length Overall (inc Guard)	13"
Nett Weight	24lbs
Part No	E5000LOWPROFILE

Suitable only for a single phase 50-60Hz A.C. power supply

DO NOT USE ON D.C. SUPPLY

Do not use your magnetic drill on the same structure when arc welding is in progress. D.C. current will earth back through the magnet and cause irreparable damage.

WARNING: THIS APPLIANCE MUST BE EARTHED!

NB: ANY MODIFICATIONS TO THIS MACHINE WILL INVALIDATE THE GUARANTEE

Operational Safety Procedure

READ BEFORE USING THE MACHINE

- When using electrical tools, basic safety precautions should always be followed to reduce the risk of electric shock, fire and personal injury.
- Ensure the magnet is off before plugging in the machine.
- Do not use in wet or damp conditions. Failure to do so may result in personal injury.
- Do not use in the presence of flammable liquids, gases or in high risk environments. Failure to do so may result in personal injury.
- Before activating the machine, inspect all electrical supply cables (including extension leads) and replace if damaged. Do not use if there are any signs of damage.
- Only use extension cables approved for site conditions.
- Before activating the machine, always check the correct function of all operational systems, switches, magnet etc.
- Before operating, the machine must be securely restrained to a fixed independent feature by using safety strap RDC4083 and stationary rings RDC4082. Affix the stationary rings into the magnet, uppermost side hole to reduce the potential free movement. Should the magnet become detached from the work piece. Failure to do so may result in personal injury.
- Always wear approved eye protectors, ear defenders and recommended PPE when operating the machine.
- Disconnect from power source when changing cutters or working on the machine.
- Cutters and swarf are sharp, always ensure that hands are adequately protected when changing cutters or removing swarf. Use a tool or brush where necessary to remove any swarf or the cutter from the arbor.
- Before operating the machine, always ensure cutter-retaining screws are secured tightly.
- Regularly clear the work area and machine of swarf and dirt, paying attention to the underside of the magnet base.
- Always remove tie, rings, watches and any loose adornments that might entangle with the rotating machinery before operating.
- Always ensure that long hair is securely enclosed by an approved restraint before operating the machine.
- Should the cutter become stuck in the work piece, stop the motor immediately to prevent personal injury. Disconnect from power source and turn arbor to and from. Do not attempt to free the cutter by switching the motor on and off. Wear safety gloves to remove the cutter from the arbor.
- If the machine is accidentally dropped, always thoroughly examine the machine for signs of damage and check that it functions correctly before resuming drilling.
- Regularly inspect the machine and check for any damaged or loose parts.
- Always ensure when using the machine in an inverted position that only the minimum amount of coolant is used and that care is taken to ensure that coolant does not enter the motor unit.
- Cutting tools may shatter, always position the guard over the cutter before activating the machine. Failure to do so may result in personal injury.
- On completion of the cut, a slug will be ejected.
- When not in use always store the machine in a safe and secure location.
- Always ensure that approved Unibor™ agents conduct repairs.

Operational Instructions

Keep the inside of the cutter clear of swarf. It restricts the operating depth of the cutter.

- Ensure that the coolant bottle contains sufficient cutting oil to complete the required operating duration. Refill as required.
- Occasionally depress the pilot to ensure cutting fluid is being correctly metered.
- To start the machine, follow the control panel operation instructions.
- ALWAYS switch off the motor by depressing the MOTOR stop button. DO NOT switch off the motor by depressing the MAGNET switch.
- Apply light pressure when commencing the cut of a hole until the cutter is introduced into the work surface. Pressure can then be increased sufficiently to load the motor. Excessive pressure is undesirable, it does not increase the speed of penetration and will cause the safety overload protection device to stop the motor, (the motor can be restarted by operating the motor start button), and may cause excessive heat which may result in inconsistent slug ejection
- Always ensure that the slug has been ejected from the previous hole before commencing to cut the next.
- If the slug sticks in the cutter, move the machine to a flat surface, switch on the magnet and gently bring the cutter down to make contact with the surface. This will usually straighten a cocked slug and allow it to eject normally.
- Apply a small amount of light oil lubricant regularly to the slide and arbor support bearing.
- Cutter breakage is usually caused by insecure anchorage, a loosely fitting slide or a worn bearing in the arbor support. (Refer to routine maintenance instructions).
- Only use approved cutting fluid do not use water diluted cutting oil.

Control Panel

(1)

PANEL OFF
NO POWER TO THE MACHINE



(2)

MAGNET ON



ONCE THE **MAGNET ON** BUTTON IS PRESSED THE **MAGNET ON** LIGHT WILL EITHER ILLUMINATE SOLID GREEN SHOWING ENOUGH ADHESION HAS BEEN ACHIEVED OR FLASH RED SHOWING NOT ENOUGH MAGNETIC ADHESION HAS BEEN ACHIEVED.

THE **MAGNET ON** WILL PERFORM AS BELOW ONCE PRESSED:

- 1) THE **MAGNET ON** LIGHT ILLUMINATES SOLID GREEN, THIS MEANS THE MACHINE IS ON MATERIALS 6MM (1/4") OR THICKER AND ENOUGH ADESION HAS BEEN ACHIEVED . THE MACHINE WILL BE MAGNETISED TO THE MATERIAL AND THE **MOTOR ON/OFF** LIGHT WILL FLASH GREEN SHOWING THE MACHINE IS SAFE TO BE OPERATED.
- 2) THE **MAGNET ON** LIGHT FLASHES RED, THIS MEANS THE MACHINE IS ON MATERIALS LESS THAN 6MM (1/4") AND NOT ENOUGH ADESION HAS BEEN ACHIEVED. THE MAGNET WILL NOT MAGNATISE AND THE MOTOR CAN NOT BE OPERATED.

(3)

MOTOR ON



ONCE THE MAGNET IS ON, THE **MOTOR ON/OFF** SWITCH WILL PULSE GREEN SHOWING THE USER THE MOTOR CAN NOW BE TURNED ON.

DEPENDING ON IF ENOUGH MAGNETIC ADHESION HAS BEEN ACHIEVED ONE OR TWO PRESSES WILL BE NEEDED TO TURN THE MOTOR ON.

(4)

MOTOR OFF



WHILE THE MOTOR IS RUNNING THE **MOTOR ON/OFF** BUTTON WILL ILLUMINATE RED.

(5)

DRILL SMART

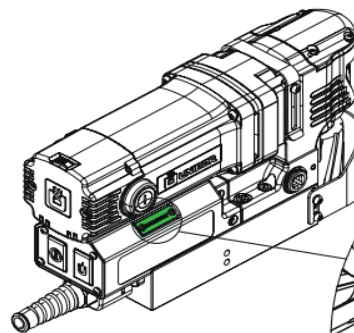

THE DRILLSMART LEDS WILL ILLUMINATE ON BOTH SIDES.

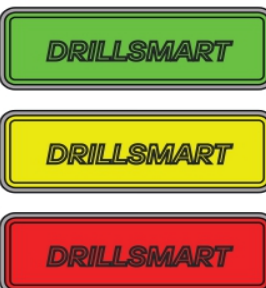
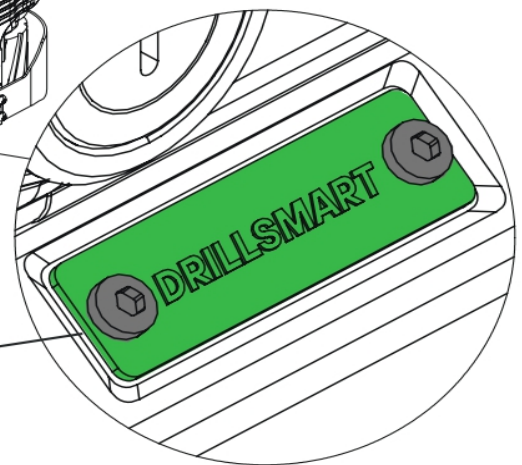

WHILE CUTTING A HOLE THE **DRILLSMART DISPLAY** WILL ILLUMINATE EITHER GREEN, YELLOW OR RED USING THE SAME TRAFFIC LIGHT SYSTEM AS DRILL SMART, BUT INSTEAD OF A SEPARATE LED, THE LED'S ARE INTERGRATED INSIDE THE SWITCH.

Extension Cable Selection

The machines are factory fitted with a 9 ¾ft length of cable having three conductors 14AWG LIVE, NEUTRAL and EARTH. If it becomes necessary to fit an extension cable from the power source, care must be taken in using a cable of adequate capacity. Failure to do so will result in a loss of traction by the magnet and a reduction of power from the motor.

Assuming a normal AC supply of the correct voltage, it is recommended that the following extension lengths shall not be exceeded:

For 120v supply: 11 ½ft of 3 core x 14AWG

ALWAYS DISCONNECT THE MACHINE FROM THE POWER SOURCE BEFORE CHANGING CUTTERS.

Mounting Of Cutters

- The machine has been made to accept cutters having 3/4" dia. Weldon shanks.

The following procedure is to be used when mounting cutters:

- Lay the machine on its side with feed handles uppermost, ensuring arbor is wound down to its lowest point to enable access to socket screws.
- Take appropriate pilot and place through the hole in cutter shank. Insert shank of cutter into bore of arbor, ensuring alignment of two drive flats with socket screws.
- Tighten both screws using hexagon key.

Troubleshooting

Magnet and motor do not function.

- Damaged or defective wiring.
- Defective fuse.
- Defective control unit.
- Defective power supply.

Magnet does function, the motor does not.

- Damaged or defective wiring
- Carbon brushes are stuck or worn out
- Defective on / off switch
- Defective control unit
- Defective armature and/or field
- Defective protective reed switch

Hole cutters break quickly, holes are bigger than the hole cutter.

- Play in the guide
- Bent spindle
- Shaft extending from the motor is bent
- Pilot bent

Motor running roughly and/or seizing up.

- Bent spindle
- Shaft extending from the motor is bent
- Triangular guide not mounted straight
- Dirt between spindle and the guide

Motor making a rattling sound.

- Armature Gear ring worn out
- Gear(s) worn out
- No grease in gear box

Motor humming, sparks and motor has no force.

- Armature damaged
- Field coil burnt
- Carbon brushes worn out

Motor does not start or fails.

- Damaged or defective wiring
- Damage to armature or field coil
- Damaged or defective brushes

Guiding takes a great deal of effort.

- Guide is set too tight
- Guide is dry
- Guide/Rack/Pinion is dirty or damaged

Insufficient magnetic force.

- Bottom of magnet not clean and dry
- Bottom of magnet not flat
- Work piece is not bare metal
- Work piece is not flat
- Work piece is too thin less than 3.5mm
- Defective control unit
- Defective magnet

Frame under voltage.

- Damaged / defective wiring
- Motor seriously dirty

Fuse blows when magnet switch is turned on.

- Damaged or defective wiring
- Wrong value fuse
- Defective magnet switch
- Defective control unit

Fuse blows when motor is started up.

- Damaged or defective wiring
- Wrong value fuse
- Motor running roughly
- Defective armature and / or field
- Carbon brushes worn out
- Defective control unit

Rotation system free stroke too long.

- Loose or defective gear-rack
- Defective rotation system

Wiring Diagram

WIRING DIAGRAM

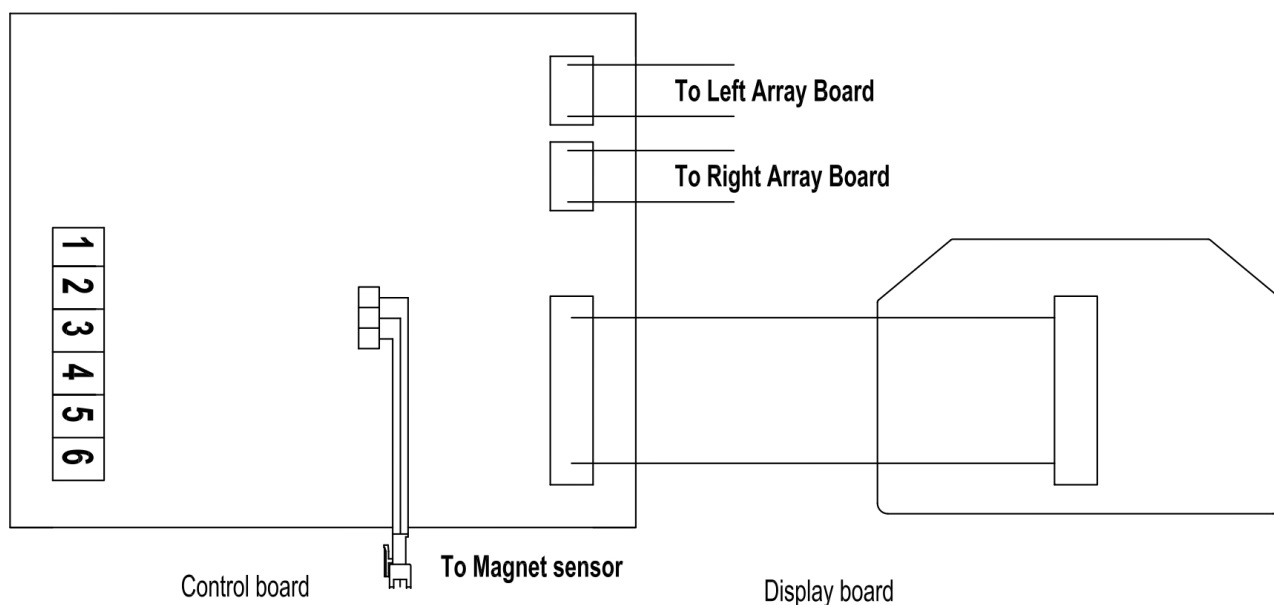

E5000LP WIRING BREAKDOWN		
No	Function	Wire Colour
1	Magnet Negative Output	Blue
2	Magnet Positive Output	Black
3	Mains Neutral Input	White
4	Motor Neutral Output	Red
5	Motor Live Output	Red
6	Mains Live Input	Black

Machine Parts

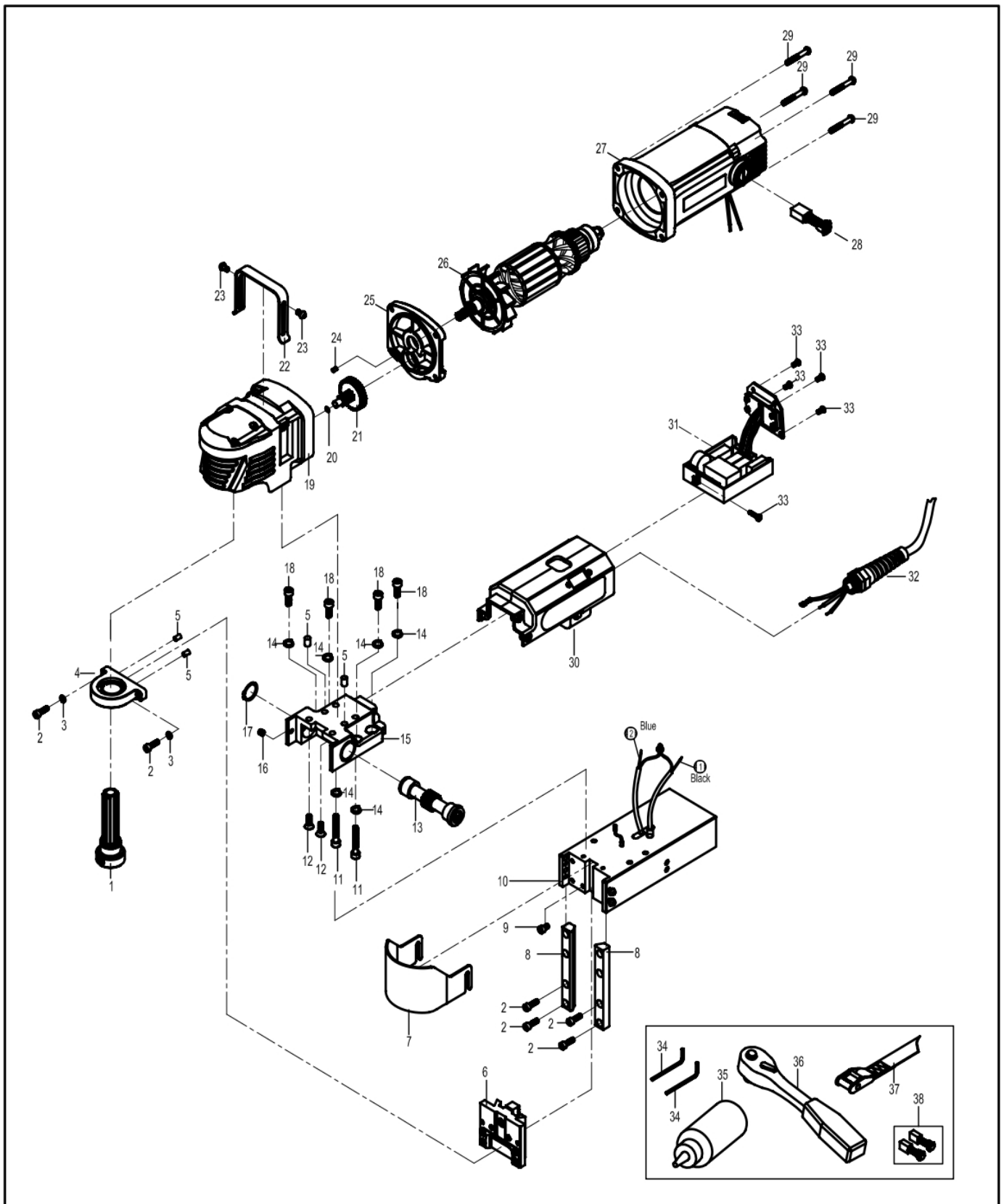

Machine Parts

E5000LP BOM			
Item#	Unibor Part Number	Description	Qty/pcs
1	RDF2000	Arbor Spindle Assembly	1
2	RDF4000	Screw	6
3	RDF4001	Circlip	2
4	RDF2040	Bearing bracket	1
5	RDF4004	Straight Pin	4
6	RDF2001	Slide assembly	1
7	RDF2041	Guard	1
8	RDF3002	Guide Bar	2
9	RDF4006	Screw	1
10	RDF2042	Magnet assembly 120V	1
11	RDF4008	Screw	2
12	RDF4009	Screw	2
13	RDF3003	Capstan spindle	1
14	RDF4010	Circlip	6
15	RDF2043	Connected base assembly	1
16	RDF4007	Screw	3
17	RDF4011	Circlip	1
18	RDF4012	Screw	4
19	RDF2044	Gear Box assembly	1
20	RDF4013	Gear Shaft Washer	1
21	RDF2005	Shaft gear assembly	1
22	RDF3004	Handle	1
23	RDF4005	Screw	2
24	RDF4014	Straight Pin	1
25	RDF2045	Inner gear plate	1
26	RDF2021/1	Armature Assembly 120v	1
27	RDF2046	Motor Frame Assembly	1
28	RDF3005/1	Carbon Brush Set 120v	1
29	RDF4015	Screw	4
30	RDF2047	Cover shell subassembly 120V	1

Machine Parts

31	RDF2048	Control Unit	1
32	RDF2049	Mains cable assembly	1
33	RDF4029	Screw	5
34	RDF4030	Hexagon spanner	2
35	RDF4031	Coolant bottle	1
36	RDF4032	Ratchet handle	1
37	RD4329	Safety strap	1
38	RDF3005/1	Spare Brush 120V	1

Pipe Adaptor Kit

FITTING INSTRUCTIONS

- Dependent upon the size of the pipe to be cut (see illustrations) attach adjustable angle plates RD3328 with cap screws RD4325 and washers RD4205 (4 off each) to the magnet sides. Do not tighten.
- Locate the machine on the center line of the pipe taking care that the magnet is in line with the longitudinal axis of the pipe.
- Switch on the magnet and move the sliding plates down to the outside diameter of the pipe. Tighten the screws on both sides by hand then check once again that the full length of the moving plates is touching the pipe at the front and back, fasten the plate securely. Feed the safety strap through the lugs at the front of the housing, around the pipe and pull tight.
- When cutting the hole DO NOT use excessive pressure but rather let the cutter ease into the cutting surface.

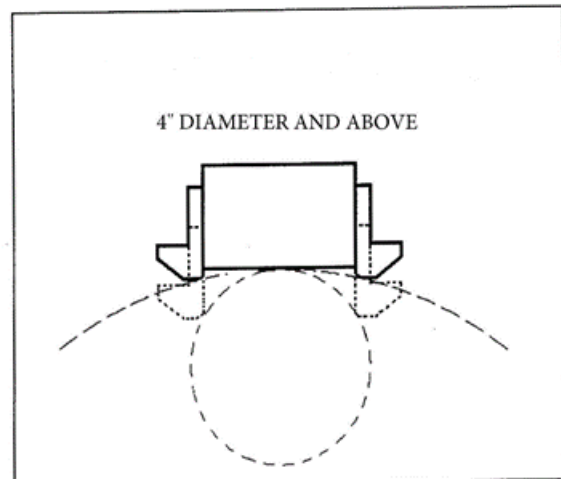
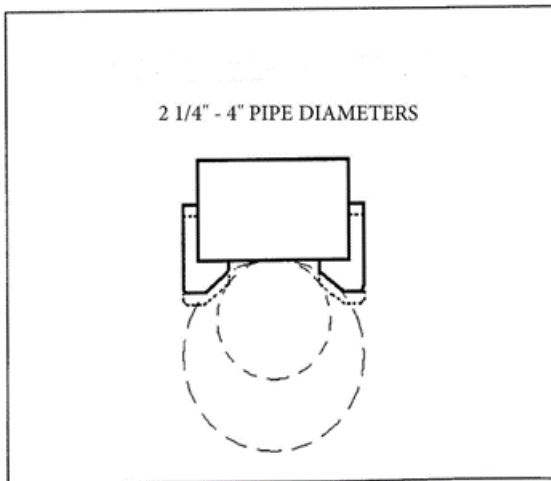

Maintenance

In order to 'get the best life' out of your Unibor machine always keep it in good working order.

A number of items must always be checked on Unibor machines.

Always before starting any job make sure the machine is in good working order and that there are no damaged or loose parts. Any loose parts must be tightened.

Before proceeding with any maintenance work be certain that the power supply is disconnected.

Description	Every operation	1 week	1 Month
Visual check of machine for damage	X		
Operation of machine	X		
Check brush wear		X	
Check magnetic base	X		
Check alignment of the machine			X
Check grease			X
Check armature			X

Visually check the machine for damage.

The machine must be checked before operation for any signs of damage that will affect the operation of the machine. Particular notice must be taken to the mains cable, if the machine appears to be damaged it should not be used, failure to do so may cause injury or death.

Check operation of the machine.

The machines operation must be checked to ensure that all components are working correctly.

Machine Brushes

Should be checked to make sure there is no abnormal wear present (this should be checked at least once a week if used frequently). If the brush has worn more than 2/3 of the original length, the brushes should be changed. Failure to do so may cause damage to the machine.

Maintenance

Magnetic base – before every operation the magnetic base should be checked to make sure that the base is flat and there is no damage present. An uneven magnet base will cause the magnet not to hold as efficiently and may cause injury to the operator.

Adjustment of slide and bearing bracket alignment.

An essential requirement of the machine is that the slide can move in a smooth and controlled manner, free of lateral movement and vibration.

This situation can be maintained by periodic adjustment of the slide and is accomplished in the following manner:

1. Place the machine in an upright position and, by means of the capstan, raise the slide to its highest position. Clean the brass gib strips and apply a small amount of light machine oil to the wear surfaces.
2. Now lower the slide back to its lowest position. Bring the slide into the center of the dovetail slide housing and loosen screws thus allowing free movement of the arbor support bracket.
3. Commencing with the middle screws, gently feed in all the screws until slight resistance is encountered.
4. Operate the slide up and down a few times to test the movement and make any further necessary adjustments. Try to ensure that all the screws are exerting a uniform pressure on the slide from top to bottom. A perfectly adjusted slide will operate freely up and down without any sideways movement.
5. Now raise the slide to its highest position. Slightly undo the arbor bearing bracket and, using fingers only, tighten the screws.
6. Place the machine on a steel plate, connect to power supply and switch on the magnet. Start up the motor. If the arbor is incorrectly aligned, the arbor support bracket will be seen to oscillate. Make any necessary further adjustments to the bracket to ensure correct alignment of the spindle and finally tighten the screws using a spanner. Lastly tighten the arbor bearing bracket.

Check machines grease.

The gearbox grease should be checked once a month to ensure all moving components are covered to prevent wear. The grease should be changed at least once a year to ensure you gain the best from your machine.

Check Armature of the machine.

This should be checked at least once a month to check that there are no visual signs of damage to the body or to the commutator. Some signs of wear will be seen on the commutator over a period of time but this is normal (this is the part that comes into contact with the brushes) however, if there are any signs of abnormal damage the part should be replaced.

Cutting Speed Selection

Material	Material Hardness	Cutter Selection
Mild and free cutting steels	<700N/mm ²	M2
Mild and free cutting steels	<850N/mm ²	M42
Steel angle and joists	<700N/mm ²	M2
Steel angle and joists	<850N/mm ²	M42
Plate and sheet steel	<700N/mm ²	M2
Plate and sheet steel	<850N/mm ²	M42
Aluminium	<750Nmm ²	M2
Aluminium	<850N/mm ²	M42
Brass	<700N/mm ²	M2
Brass	<850N/mm ²	M42
Cast iron	<700N/mm ²	M2
Cast iron	<850N/mm ²	M42
Stainless steel	<700N/mm ²	M2
Stainless steel	<850N/mm ²	M42
Stainless steel	>850N/mm ²	TCT
Rail track	>850N/mm ²	M42
Tool steel	>850N/mm ²	TCT
Die Steel	>850N/mm ²	TCT

Warranty Statement

Unibor™ warrants its machines to be free from faulty parts, under normal usage of machines, for a period of 12 months from initial date of purchase. All other parts (excluding cutters) are under warranty for 90 days, provided that the warranty registration card (or online registration) has been completed and returned to Unibor™ or its designated distributor within a period of (30) days from the purchase date. Failure to do so will void the warranty.

If the stated is adhered to, Unibor™ will repair or replace (at its option) without charge any faulty items returned.

This Warranty does not cover:

1. Components that are subject to natural wear and tear caused by the use is not in accordance with the operator's instructions
2. Defects in the tool caused by non-compliance with the operating instructions, improper use, abnormal environment conditions, inappropriate operating conditions overload or insufficient servicing or maintenance.
3. Defects caused by using accessories, components or spare parts other than original Unibor™ parts.
4. Tools to which changes or additions have been made.
5. Electrical components are subject to manufacturer's warranty.

The warranty claim must be logged within the warranty period. This requires the submission or sending of the complete tool in question with the original sales receipt which must indicate the purchase date of the product. A complaint form must also be submitted prior to the return.

This can be found online at www.uniborusa.com. Failure to complete this form will result in the delay of your claim. All goods returned defective must be returned pre-paid to Unibor™, in no event shall Unibor™ be liable for subsequent direct, or indirect loss or damage.

THIS WARRANTY IS IN LIEU OF ANY OTHER WARRANTY, (EXPRESSED OR IMPLIED) INCLUDING ANY WARRANTY OF MERCHANTABILITY OR FITNESS FOR A PURPOSE. UNIBOR™ RESERVE THE RIGHT TO MAKE IMPROVEMENTS AND MODIFICATIONS TO DESIGN WITHOUT PRIOR NOTICE

Known and Trusted Worldwide for Quality, Performance and Reliability

Extra

Extra

Extra



Extra

Extra

Extra



UNIBOR™